



YOU CAN TRUST



YOU CAN TRUST

## INSTRUCTIONS MANUAL



Skyfood Equipament LLC

**OFFICE**

175 SW 7th Street - Suite # 2416

Miami, FL 33130

**1-800-503-7534 | 305-868-1603**

UG0204 - INGLÊS

Data de Correção: 05/07/2019

SLICERS

SSI-12E

SSI-12I

SSI-14I

- BESIDES THIS EQUIPMENT, A COMPLETE RANGE OF OTHER PRODUCTS ARE MANUFACTURED, CONSULT OUR DEALERS  
- DUE TO THE CONSTANT IMPROVEMENTS INTRODUCED TO OUR EQUIPMENTS, THE INFORMATION CONTAINED IN THE PRESENT  
INSTRUCTION MANUAL MAY BE MODIFIED WITHOUT PREVIOUS NOTICE.

[www.skyfood.us](http://www.skyfood.us)

# SUMMARY

GENERAL WARNINGS.....	3
1. PACKING .....	8
2. TECHNICAL DESCRIPTION AND INTENDED CONDICTIONS OF USE .....	11
2.1 General description .....	11
2.2 Environmental condicions of the machine use .....	11
2.3 Slicer correct use .....	11
3. MECHANICAL SAFETY DEVICES AND ELECTRICAL PARTS.....	12
3.1 Residual risks.....	12
4. INSTALLATION AND PRELIMINARY CHECKS.....	21
4.1 Installation .....	21
4.2 Electric connection .....	21
4.3 Control of operation and blade rotation direction .....	22
5. USING THE MACHINE.....	23
5.1 Loading the product on the tray.....	23
5.2 Slicing the product.....	23
6. CLEANING THE SLICER.....	24
6.1 Components disassembly .....	24
6.2 Base cleaning.....	25
6.3 Cleaning the blade.....	26
6.4 Reassembling the machine .....	26
7. MAINTENANCE .....	27
7.1 Generalities .....	27
7.2 Blade sharpening.....	27
8. PERFORMING THE SHARPENING .....	28
8.1 Versions with sharpener .....	28
8.2 Versions with built-in sharpener .....	31
9. LUBRICATION .....	33
9.1 Tray sliding guides and product grip sliding rod (weekly).....	33
10. TAKING THE SLICER OUT OF SERVICE.....	35
11. TROUBLESHOOTING.....	36
SKYFOOD EQUIPMENT LLC - SERVICE .....	69
SKYFOOD'S LIMITED WARRANTY .....	69

## Warranty Registration



Questions about how to complete this form?  
 Call 1-800-503-7534 / 305-868-1603  
 Return completed form to:  
 SKYFOOD EQUIPMENT LLC  
 11900 Biscayne Blvd. Suite 616  
 North Miami, FL 33181 - USA  
 Or fax form to:  
 305-866-2704

### User Details

**Contact Person:** \_\_\_\_\_  
 **Business type:**  

<input type="checkbox"/> Bakery and Bagel Operations	<input type="checkbox"/> Misc Merchandiser with Grocery
<input type="checkbox"/> Bakery (Associated with Restaurant)	<input type="checkbox"/> Misc Merchandiser with NO Grocery
<input type="checkbox"/> Baking Center	<input type="checkbox"/> Meat Packer and Purveyor
<input type="checkbox"/> Business and Industry In-House Feeding	<input type="checkbox"/> Other Business that prepares or serves food
<input type="checkbox"/> Butcher	<input type="checkbox"/> Other Business that sells but doesn't serve food
<input type="checkbox"/> Catering	<input type="checkbox"/> Pica (Dive In / Carry-Out)
<input type="checkbox"/> Club Stores	<input type="checkbox"/> Restaurants (Independent / Chain)
<input type="checkbox"/> Convenience Store	<input type="checkbox"/> School
<input type="checkbox"/> Country Club	<input type="checkbox"/> Stadium / Coliseum
<input type="checkbox"/> Delicatessen (Chain / Restaurant)	<input type="checkbox"/> Supermarket / Grocery
<input type="checkbox"/> Delicatessen (Independent and Non-Restaurant)	<input type="checkbox"/> Theme Park
<input type="checkbox"/> Food Store	<input type="checkbox"/> University / College
<input type="checkbox"/> Government	<input type="checkbox"/> Vineyard / Winery
<input type="checkbox"/> Hospital	<input type="checkbox"/> Warehouse Clubs
<input type="checkbox"/> Lodging	<input type="checkbox"/> Wholesale Baking Operations (Non-Institutional)

**Company Name:** \_\_\_\_\_  
 **Address:** \_\_\_\_\_  
 **City:** \_\_\_\_\_  
 **State:** \_\_\_\_\_  **Zip Code:** \_\_\_\_\_  
 **Phone:** \_\_\_\_\_  **Fax:** \_\_\_\_\_  
 **E-mail:** \_\_\_\_\_  
 **Web page:** \_\_\_\_\_  
 I would like to join the Mail List.  I would like to join the E-mail List.

### Product Details

**Product Commercial Item:** \_\_\_\_\_  
The Product Commercial Item can be found on the product identification label.  
 **Serial Number:** \_\_\_\_\_  **Confirm Serial Number:** \_\_\_\_\_  
In addition, the Product Identification number is found on the machine Product Identification Label.  
 **Proof of Purchase:**  Yes  No  
 **Purchased On:** \_\_\_\_ / \_\_\_\_ / \_\_\_\_ (mm / dd / yyyy)  
 **Purchased From:** \_\_\_\_\_  
Company Name

\* Indicates required field. \*\* Indicates required field, not mandatory by Fax

## GENERAL WARNINGS

### Safety warnings indispensable before use.

to SKYFOOD's facility or to a Service Company. Mileage or travel time will NOT be paid. SKYFOOD offers a limited on-site warranty for products ONLY held at commercial facilities, whose net weight exceeds seventy (70) lbs., provided they are installed in a location that is within a thirty (30) mile radius of a Service Company. **End Users are responsible for all extra travel and mileage rates.** In this case, warranty services will be provided during regular business hours.

**This product will be replaced or repaired under warranty, for a period of (1) year, beginning from the date of purchase by the original purchaser/user ("End User"), or eighteen (18) months from the date of shipment from SKYFOOD's warehouse, whichever expires first.**

Accessories will be replaced or repaired under warranty, for a period of (30) days, beginning from the date of purchase by the original purchaser/user ("End User"), or eighteen (18) months from the date of shipment from SKYFOOD's warehouse, whichever expires first.

This warranty shall not take effect until a properly completed and executed **WARRANTY REGISTRATION** form has been received by SKYFOOD EQUIPMENT, LLC, within thirty (30) days from the date of purchase. The **WARRANTY REGISTRATION** is available either in the Instruction Manual of every Product or at SKYFOOD's website [www.skyfood.us](http://www.skyfood.us). The End User must fill out the **WARRANTY REGISTRATION** form and send it to SKYFOOD according to the instructions posted on the referred website. **Failure to do so will VOID the warranty.**

**No extended warranties for third party products. There are no other express warranties or conditions other than the one offered by each manufacturer for products sold by SKYFOOD, not under the SKYFOOD brand.**

For questions or assistance, do not return the product or accessories to the store, please call Toll Free 1-800-503-7534, or visit the Customer Service section at [www.skyfood.us](http://www.skyfood.us). For faster service please have the items name, serial number, and proof of purchase for the operator to assist you.

**SKYFOOD reserves the right to change the terms of its limited warranty at any time without any prior notice. It also reserves the right to change the design and specifications of its equipment or any related documentation at any time. The end user is not entitled to upgrades or refunds resulting from these changes.**

#### Updates

These **Terms and Conditions** were last updated on May 2<sup>nd</sup>, 2016.

#### WARNING

**Carefully read the warnings contained in these instructions as they supply important indications regarding installation, use and maintenance safety of the gravity slicers for food.**

The purpose of this publication, simply described as 'booklet' below, is to allow to the consumer, especially to the direct user, to take all the necessary human and material measures for a safe and long use of the machines. This manual **MUST** be preserved throughout the whole life of the slicer and in case of necessity (example: damage which compromises its consultation even partially, etc.) the user must request a new copy to the manufacturer.

## GENERAL WARNINGS

In case of a slicer sale, deliver this manual to the new owner too.

The installation must be carried out according to the manufacturer's instructions. Incorrect installation can cause harm to people, animals or properties in respect of which the manufacturer can not be held responsible.

### WARNING

**Children should not use the device as a toy and should neither clean nor use the equipment.**

### WARNING

**Keep children away from the device and from the power cord.**

### WARNING

**The appliance must be used by adults adequately trained for the purpose who have carefully read the content of this manual.**

The package elements (plastic bags, expanded foam, etc.) must not be left in the range of children as they are potential danger sources.

### WARNING

**Electrical safety of this appliance is assured only when it is correctly connected to an efficient grounding system as specified by current electrical safety standards.**

You should check this fundamental safety requirement and, if in doubt, require an accurate control of the system by professionally qualified personnel.

**The manufacturer can not be held responsible for any damage caused by the lack of grounding of the system.**

### SKYFOOD EQUIPMENT LLC - SERVICE

For questions or assistance, call SKYFOOD EQUIPMENT Toll Free: 1-800-503-7534, or visit the Customer Service section at [www.skyfood.us](http://www.skyfood.us).

### SKYFOOD'S LIMITED WARRANTY

Unless otherwise specified, new SKYFOOD products, excluding accessories, sold by SKYFOOD EQUIPMENT, LLC. ("SKYFOOD"), for use only in the continental United States (collectively, "Products" or singularly, "Product"), are warranted to be free from defects in materials and workmanship for a period of one (1) year from the date of purchase by the original purchaser/user ("End User"), or eighteen (18) months from the date of shipment from SKYFOOD's warehouse, whichever expires first. Several new products and accessories may be warranted for a period other than one (1) year while others may be subject to travel limitations, as specified on the products Instruction Manual. **Proof of purchase must be presented; if not this warranty will be VOID.** No warranty is given or implied to a subsequent transferee or any other third party. This warranty is expressly conditional upon SKYFOOD being notified of any defects in materials or workmanship within five (5) days of its occurrence, within the warranted time period. If a notice of a claim under this warranty is timely made by the End User, SKYFOOD or a SKYFOOD's designated service company ("Service Company"), will repair or replace the Product, at SKYFOOD's discretion, subject to the additional conditions hereinafter described.

This warranty shall not apply if damage occurs from improper installation or maintenance performed by an unauthorized service company ("Service Company"), wrong voltage, nor to the extent that Products or parts have been used other than in conformance with operating and maintenance instructions, subjected to misuse or abuse or damaged by accident, acts of God, abnormal use, stress or any other matter unrelated to SKYFOOD, and beyond its reasonable control. **This warranty does NOT cover service labor and travel to perform adjustments on products and/or accessories.** In addition to wear and tear of certain items, such as, but not limited to; glass parts, blades, stones, chopper cutting knives, plates, slicing knives, cutting disc, gaskets, oil changes, sealing tape, heat seal wires, worm gears, self-lubricating bushings, carbon brushes for electric motors, and other parts expendable by nature and that need to be replaced frequently. **Electrical components are subject to natural wear and tear, and are NOT covered by this warranty. THIS WARRANTY EXCLUDES ALL ORAL, STATUTORY, EXPRESS OR IMPLIED WARRANTIES WHICH MAY BE APPLICABLE TO SKYFOOD, INCLUDING, BUT NOT LIMITED TO, ANY IMPLIED WARRANTY OF MERCHANTABILITY AND FITNESS FOR PARTICULAR PURPOSE.** Under no circumstances shall SKYFOOD be liable for loss of use, revenue or profit or for incidental or consequential damages. SKYFOOD shall under no circumstances be liable for any loss, damage, concealed damage, expense or delay of goods for any reason when said goods are in the custody, possession or control of third parties selected by SKYFOOD to forward, enter, clear, transport, or render other services with respect to such goods. The sole and exclusive remedy for breach of any warranty is limited to the remedies provided in the paragraph above.

All products held at non-commercial facilities or domiciles, must be taken or shipped, shipping charges prepaid, either to SKYFOOD's facility or a SKYFOOD's designated service company ("Service Company"). Products held at commercial facilities and weighing less than seventy (70) lbs. must be taken or shipped, shipping charges are prepaid, either

Manufacturer:

Declaration of conformity



CE HOUSEHOLD USE

The undersigned....., legal representative of the Company..... based in....., and person authorized to compile the technical file, declares that the SLICER

Version: \_\_\_\_\_ Serial N.: \_\_\_\_\_ Year: \_\_\_\_\_

complies, where applicable, with the following protection directives:

- Directive 2014/35/EU (Low Voltage Directive BT)
- Directive 2014/30/EU (Electromagnetic Compatibility EMC)
- 1935/2004/EEC Regulation on materials and articles intended to come into contact with food products
- Directive 2011/65/EU (environmental safety related the disposal of electric and electronic devices)
- Directive 2002/95/EC (RoHS I)

And to the following HARMONISED RULES

- EN ISO 12100:2010 - Machinery Safety
- EN 60335 -1:2012/A11:2014 - Household and similar electrical appliances safety
- EN 60335-2-64:2003/A11:2012-Household and similar electrical appliances safety

The signatory firm of the present one undertakes to forward, in response to a properly motivated request of the national authorities, relevant information to the machine subject of this declaration, without prejudice the rights of intellectual property of the machine's manufacturer. Information will be transmitted directly to the national authority which requested them.

Place,

**ORIGINAL**

Legal representative signature

.....

- Before plugging the appliance make sure that the data on the label correspond to those of the electrical distribution network.
- The plate is on the bottom of the appliance.
- For your safety, it is recommended to power the device through a circuit breaker (DRC) with trip current not exceeding 30 mA.
- In case of incompatibility between the socket and the plug of the appliance, have the die-casted cord and plug replaced with another one by an authorized dealer. In case of tampering the manufacturer cannot be held responsible either for safety or for warranty. Alternatively have the socket replaced with a suitable type by a qualified professional. The latter, in particular, will also have to ensure that the section of the socket cables is suitable for the power absorbed by the appliance. In general it is not advisable to use adapters, multiple sockets and/or extensions.
- Do not connect the appliance to the power supply via external timer or remote control systems.
- The use of any electrical appliance requires the observance of some basic rules. In particular:
  - do not touch the appliance with wet hands
  - do not use the appliance barefooted
  - do not pull the power cord or the appliance itself to remove the plug from the socket
  - do not leave the appliance exposed to atmospheric agents (rain, sun, etc.)
  - do not move the appliance while it's functioning.
  - the appliance has not been designed to be used under rain and must not be stored outdoor or in moist places.
- In case of failure and / or malfunction, turn it off and do not tamper it. For repairs apply only to the manufacturer or to a service center authorized by the same and require the use of genuine spare parts. Failure to comply with the above may compromise the security of the device.

If you decide not to use a device of this type any more, it must be made inoperative by cutting the power cord after removing the plug from the socket. It is also recommended to make harmless those parts of the equipment which may constitute a danger, especially for children who might use an abandoned appliance for their games.

- To avoid dangerous overheating, it is recommended to extend the power cord to its full length and to use the appliance as recommended in “USING THE MACHINE”.

**WARNING**

**During functioning, the outlet must be easily accessible in case it's necessary to disconnect the appliance. Do not place the appliance under a power socket so that the cord doesn't interfere with the machine correct use.**

- Do not leave the appliance plugged in unnecessarily. Unplug it from the power supply when is not used.
- At the end of use always turn the appliance off and disconnect the plug from the power socket.
- At the end of each use always perform an accurate cleaning of all the parts in contact with food, as indicated in the item “Cleaning”.
- Do not block the openings, ventilation or heat dissipation slots.
- If the power cord of this appliance is damaged, it must be replaced by a service center authorized by the manufacturer, as special tools are required.

**WARNING**

**Before performing any operation, turn the appliance off and disconnect the power plug from the power socket.**

Make sure the power cord does not protrude from the floor to avoid that someone can pull it also inadvertently knocking the appliance.

Place the appliance on a horizontal and firm supporting plane, whose surface is not sensitive (eg. Lacquered furniture, tablecloths etc.). Make sure that the appliance is safely supported.

Do not place the appliance on or near heat sources.

**WARNING**

**Place the appliance away from sinks and taps.**

For slicer models with details in olive wood, the following tests were performed:

*Screening of inorganic compounds in materials in contact with the foodstuffs*

with the purpose of detecting and quantifying the molecules extractable from the sample by contact with 65% nitric acid at 120°C for 2 hours and detectable by plasma emission spectrometry (ICP/OES).

*Screening of volatile organic compounds in materials in contact with the foodstuffs*

with the purpose of evaluating the transfer of volatile substances making up the material that can migrate into the foodstuff by conditioning at a suitable temperature, extraction of the head space (via 30 minute contact at 125°C) and gas chromatographic analysis with mass detector.

*Screening of semi-volatile organic and non-volatile compounds in materials in contact with the foodstuffs*

with the purpose of detecting and quantifying, conventionally in benzyl butyl phthalate (BBPd4), the molecules extractable from the sample by contact with 95% ethanol at 60°C for 10 days and detectable by gas chromatography equipped with mass detector (GC EI/MS).

The following Test Reports relative to the migration test performed are available at <http://www.slicers.it> in the reserved area

Test report n°8395-05 Bpsec S.r.l.

Report – 8395-05 Bpsec S.r.l. Elements

Report – 8395-05 SVOC Bpsec S.r.l.

Report – 8395-05 VOC Bpsec S.r.l.

NAME	CAS	Value detected	QM(t) mg/kg
4,4'-methylene (phenylisocyanate)	cas 101-68-8	0,0120	1

Since the value detected is lower than the QM(t) value, the slice is deemed compliant.

#### TEST CONDITIONS

#### MIGRATION IN WATER MIGRATION IN OIL

Met.: BS EN 1186:2006 Met.: BS EN 1186:2006

#### CONTACT CONDITIONS

Surface/volume ratio: .....0,4  
 Time.....30 min  
 Temperature.....40°C

#### CONTACT CONDITIONS

Surface/volume ratio:..... 0,4  
 Time..... 30 min  
 Temperature.....40°C

The simulants and test conditions are selected on the basis of the Directives 82/711/EEC and 85/572/EEC and as amended and Decree n.338 dated 22/07/1998. (See note at the end of the document regarding art. 22 of Reg. (EU) n.10/2011 on Transitional Provisions).

The overall migration limit, along with the other restrictions/specific migrations to which the monomers and/or additives present in the material are subjected, are respected in the conditions of use mentioned above. The affirmation is supported by analytical tests performed in compliance with the Directives 82/711/EEC, 85/572/EEC and 97/48/EC and with Italian Ministerial Decree 21/03/1973 or on the basis of the calculations carried out considering the content of the substances subjected to migration limits. The calculations were made assuming that 1 kg foodstuff comes into contact with 1 product.

The material contains substances governed by Regulations (EC) n. 1333/2008 and 1334/2008 and as amended (substances called "dual use").

According to experimental data and/or theoretical calculations, these substances are compliant pursuant to art. 11 of Regulation (EU) n.10/2011 paragraph 3, letters a and b and of Italian Ministerial Decree 21/03/73.

This declaration is valid from the date shown below and will be previously replaced if changes are made to production/formulation of the material or if the references to legislation in point 1 are modified and updated in a way to require a new verification to confirm conformity.

NOTE: this declaration is drawn-up pursuant to art. 22, paragraph 1: "Transitional Provisions" and art. 23 "Coming into force and application" of the Regulation (EU) n.10/2011.

The following Test Reports relative to the migration test performed are available at <http://www.slicers.it> in the reserved area

- Test report n°8395-01 Bpsec S.r.l.
- Test report n°8395-02 Bpsec S.r.l.
- Test report n°8395-03 Bpsec S.r.l.
- Test report n°8395-04 Bpsec S.r.l.

The blades are sharp; handle with care.

Do not use the appliance if the blades are damaged.

Never immerse the appliance in water.

Do not use the appliance in environments containing explosive, combustible gases or flammable liquids (paints, glues, spray cans, etc.).

#### **DANGER OF EXPLOSION AND FIRE.**

- This appliance is intended for a domestic and non EC countries use.

This appliance will have to be intended only for the use for which it has been expressly conceived, namely to slice food products (see paragraph 2.3) with reference to the standards indicated in the declaration of conformity. Any other use is considered improper and dangerous. The manufacturer can not be held responsible for any damage caused by improper, erroneous and unreasonable use.

**WARNING**  
**Do not remove the safety devices and do not modify or exclude the mechanical and electrical safety devices.**

Always use protective scratchproof gloves for cleaning and maintenance.

Do not operate the empty appliance.

In case of problems with the appliance, contact an authorized service center.

Do not attempt to repair the device yourself.

Any repair work carried out on the device by unauthorized personnel will void the warranty even if its life had not come to an end.

In case of doubts about the content of this instruction manual or for clarifications, please immediately contact the manufacturer or the authorized technical assistance service quoting the paragraph number regarding the topic which interests you.

No part of this publication shall be reproduced or transmitted without written permission from the manufacturer.

Use the machine with great concentration, DO NOT get distracted!

- Do not wear loose-fitting clothes particularly with open sleeves; where necessary use suitable headgear to cover hair.
- When slicing, do not allow anyone to approach the slicer, especially the blade.

## 1. PACKING

### 1.1 Unpacking

When taking delivery of the slicer, ensure that the packaging is fully intact; if this is not the case, please advise the courier or local dealer immediately.

In order to remove the slicer from the packaging, please proceed as follows:

- Cut and remove the plastic bands.
  - Open the box and take out the instruction booklet.
  - Proceed as described hereafter.
- Remove the safeguards (carton and polyurethane foam) inside the box.  
- Lift the machine with great care and place on a solid surface.  
- Remove the plastic bag in which the slicer is wrapped.

Check that all components specified in the delivery note and this instruction booklet are present and fully intact.

- Should any faults be noted, such as:
  - dents to the frame or guards;
  - controls that are either not working or broken;
  - missing items or other problems; please advise the courier, manufacturer and service centre immediately.
  - Carefully dispose of packaging components (bands, cardboard, polystyrene, polythene bags, etc.) as reported below and in accordance with the standards of the Country of use.

### GUIDE TO THE TREATMENT OF WASTE EQUIPMENT

#### **This product complied with Directive 2002/19/UE.**

The crossed out wheeled bin symbol on equipment indicates that it must be treated separately from household waste at the end of its working life and therefore taken to a recycling facility for electrical and electronic equipment or handed over to the reseller when purchasing new equipment of the same type. The user is responsible for consigning the equipment to appropriate collection facilities at the end of its working life or face the penalties provided for by current waste management legislation. Separate collection for subsequent delivery of waste equipment to environmentally-compatible recycling, treatment and disposal facilities to prevent possible negative impacts on the environment and human health whilst encouraging recycling of the product's components. For further information regarding the available collection facilities, please contact your local refuse collection service or the shop in which the purchase was made. Manufacturers and/or importers fulfil their obligations concerning environmentally-compatible recycling, treatment and disposal either directly or by joining a collective scheme.

*Screening of semi-volatile organic and non-volatile compounds in materials in contact with the foodstuffs*

with the purpose of detecting and quantifying, conventionally in benzyl butyl phthalate (BBPd4), the molecules extractable from the sample by contact with 95% ethanol at 60°C for 10 days and detectable by gas chromatography equipped with mass detector (GC EI/MS).

The following Test Reports relative to the migration test performed are available at <http://www.slicers.it> in the reserved area

Test report n°8395-05 Bpsec S.r.l.  
Report – 8395-05 Bpsec S.r.l. Elements  
Report – 8395-05 SVOC Bpsec S.r.l.  
Report – 8395-05 VOC Bpsec S.r.l.

DECLARATION OF CONFORMITY OF THE MATERIALS AND OBJECTS DESTINED TO COME INTO CONTACT WITH FOOD PRODUCTS

1. With this document, it is declared that the product/article/machinery:

VERTICAL GRAVITY SLICER WITH PAINTED STRUCTURE FLYWHEEL  
supplied for prolonged contact with foodstuffs;

#### **IS COMPLIANT**

WITH THE FOLLOWING EUROPEAN COMMUNITY LEGISLATION:

- Regulation 1935/2004 EC
- Regulation 1895/2005 EC
- Regulation 10/2011 EC

AND THE FOLLOWING ITALIAN LEGISLATION:

- Ministerial Decree 21/03/1973 and as amended, including MD 140/2013
- Italian Presidential Decree 777/82 and as amended

2. The blade of the afore-mentioned slicer is manufactured with the following alloy:

- AISI 420, C45 \_ All domestic CE models and models with blade diameter from 195 to 250 mm CE professional
- AISI 420, 100Cr6 models with blade diameter from 300 to 370 mm CE professional

FOODSTUFF SUITABILITY TEST

The material respects the overall migration and specific migration limits of nickel, chrome and manganese in the test condition given by the producer supplier of the CHIARAVALLI GROUP SPA AND SLAYER BLADE SRL blade;

The slicer coating material contains substances subjected to restrictions in the legislation stated:

Component	Result	Unit of measurement	Method	Limit of release (mg/kg)
Aluminium	< 0,010	mg/kg	MP 1895 rev 0 2010	5

The simulants and test conditions are selected on the basis of the Directives 82/711/EEC and 85/572/EEC and as amended and Decree n.338 dated 22/07/1998. (See note at the end of the document regarding art. 22 of Reg. (EU) n.10/2011 on Transitional Provisions).

The overall migration limit, along with the other restrictions/specific migrations to which the monomers and/or additives present in the material are subjected, are respected in the conditions of use mentioned above. The affirmation is supported by analytical tests performed in compliance with the Directives 82/711/EEC, 85/572/EEC and 97/48/EC and with Italian Ministerial Decree 21/03/1973 or on the basis of the calculations carried out considering the content of the substances subjected to migration limits. The calculations were made assuming that 1 kg foodstuff comes into contact with 1 product.

The material contains substances governed by Regulations (EC) n. 1333/2008 and 1334/2008 and as amended (substances called "dual use").

According to experimental data and/or theoretical calculations, these substances are compliant pursuant to art. 11 of Regulation (EU) n.10/2011 paragraph 3, letters a and b and of Italian Ministerial Decree 21/03/73.

This declaration is valid from the date shown below and will be previously replaced if changes are made to production/formulation of the material or if the references to legislation in point 1 are modified and updated in a way to require a new verification to confirm conformity.

NOTE: this declaration is drawn-up pursuant to art. 22, paragraph 1: "Transitional Provisions" and art. 23 "Coming into force and application" of the Regulation (EU) n.10/2011. The following Test Reports relative to the migration test performed are available at <http://www.slicers.it> in the reserved area

Test report n°7778-01 Bpsec S.r.l.  
 Test report n°7778-02 Bpsec S.r.l.  
 REPORT n°7778-01 Bpsec S.r.l.  
 REPORT n°7778-02 Bpsec S.r.l.

For slicer models with details in olive wood, the following tests were performed:

*Screening of inorganic compounds in materials in contact with the foodstuffs*

with the purpose of detecting and quantifying the molecules extractable from the sample by contact with 65% nitric acid at 120°C for 2 hours and detectable by plasma emission spectrometry (ICP/ OES).

*Screening of volatile organic compounds in materials in contact with the foodstuffs*

with the purpose of evaluating the transfer of volatile substances making up the material that can migrate into the foodstuff by conditioning at a suitable temperature, extraction of the head space (via 30 minute contact at 125°C) and gas chromatographic analysis with mass detector.

The packing components (bands, cardboard, polystyrene, etc.) are products assimilable to the urban solid refusals.

**DO NOT DISPERSE THE PACKAGING PRODUCTS IN THE ENVIRONMENT!**

Figure 01

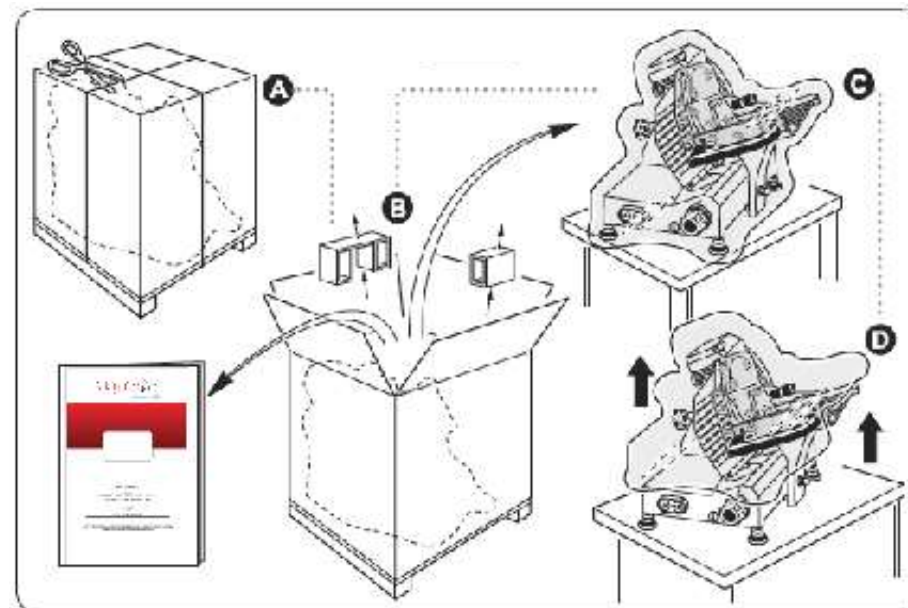

**PLATES - CONFORMITY MARKINGS**

The device described in this manual is produced in accordance with the directives in force, as amended. All component parts are adapted to the requirements of the Directive and the CE mark testifying the compliance. The plate with the identification of the manufacturer, the machine technical specifications and the CE marking is located on the base of the slicer (figure 2).

The plate must never be removed and must always be legible.  
**In case of wear or damage the user is required to replace it.**

## MOCA DECLARATION

DECLARATION OF CONFORMITY OF THE MATERIALS AND OBJECTS DESTINED TO COME INTO CONTACT WITH FOOD PRODUCTS

1. With this document, it is declared that the product/article/machinery:  
**VERTICAL GRAVITY SLICER WITH ANODISED ALUMINIUM STRUCTURE**  
supplied for prolonged contact with foodstuffs;

**IS COMPLIANT**

WITH THE FOLLOWING EUROPEAN COMMUNITY LEGISLATION:

- Regulation 1935/2004 EC
- Regulation 1895/2005 EC
- Regulation 10/2011 EC

AND THE FOLLOWING ITALIAN LEGISLATION:

- Ministerial Decree 21/03/1973 and as amended, including MD 140/2013
- Italian Presidential Decree 777/82 and as amended

2. The blade of the afore-mentioned slicer is manufactured with the following alloy:

- AISI 420, C45 \_ All domestic CE models and models with blade diameter from 195 to 250 mm CE professional
- AISI 420, 100Cr6 models with blade diameter from 300 to 370 mm CE professional FOODSTUFF SUITABILITY TEST

The material respects the overall migration and specific migration limits of nickel, chrome and manganese in the test condition given by the producer supplier of the CHIARAVALLI GROUP SPA AND SLAYER BLADE SRL blade;

The material used to manufacture the slicer and its surface treatment are subjected to restrictions in the legislation stated:

- Regolamento (CE) n. 1935/2004 of the European Parliament and of the Council of 27 October 2004 on materials and articles intended to come into contact with food and repealing Directives 80/590/EEC and 89/109/EEC

- Technical Document "Metals and alloys used in food contact materials and articles" (Council of Europe, 2013)

- DIN 10531:2011 Food hygiene - Production and dispense of hot beverages from hot beverage appliances - Hygiene requirements, migration test

To perform the analysis, a specimen was put into contact with 5000 ml of water simulant for 2 hours at 40°C at third contact.

Aluminium was searched for on the simulant coming from the contact using the ICP-MS technique.

Figure 02

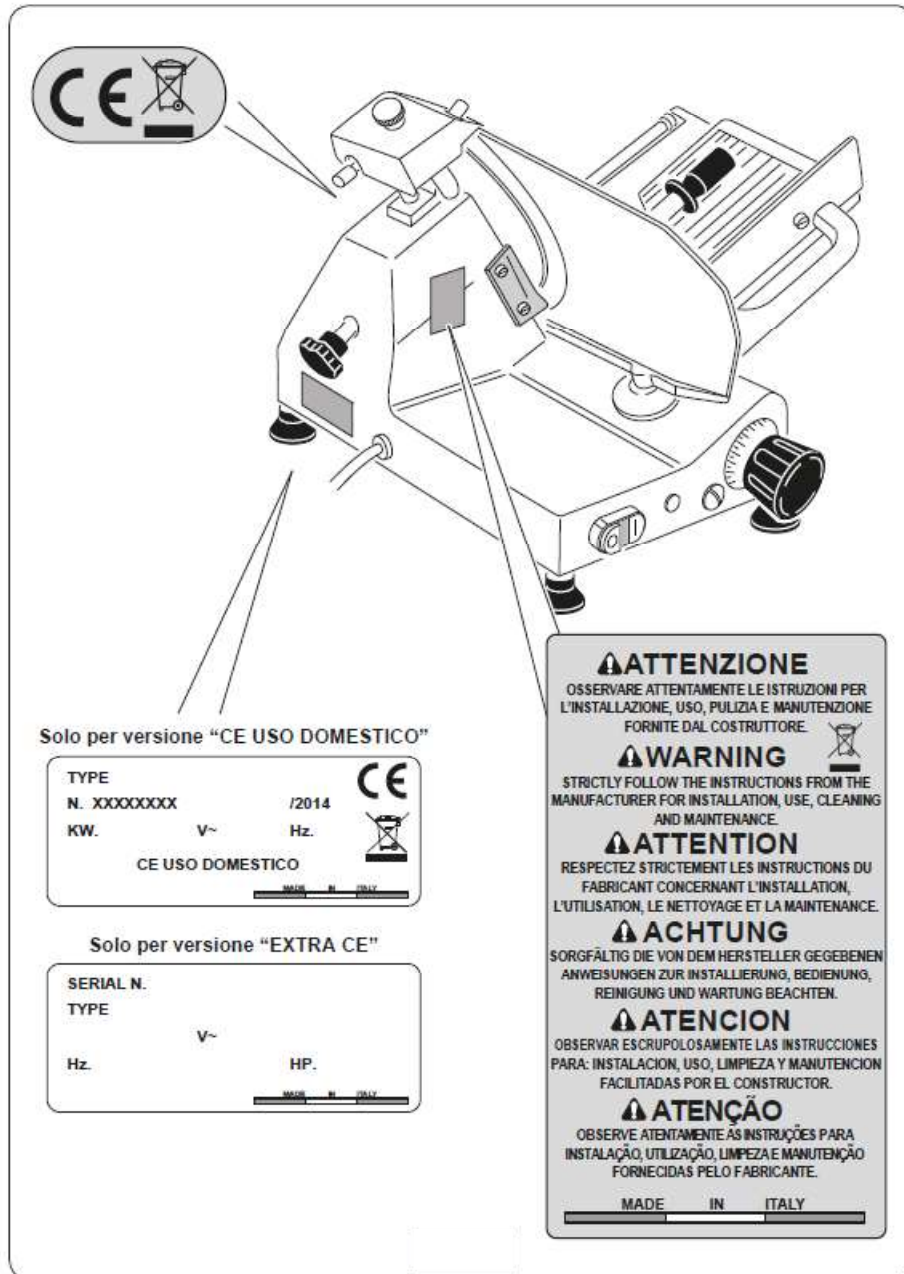

## SCOPE OF SUPPLY AND ACCESSORIES

### PRODUCT TRAY

**Fig. 8**

Ed, 01/2009

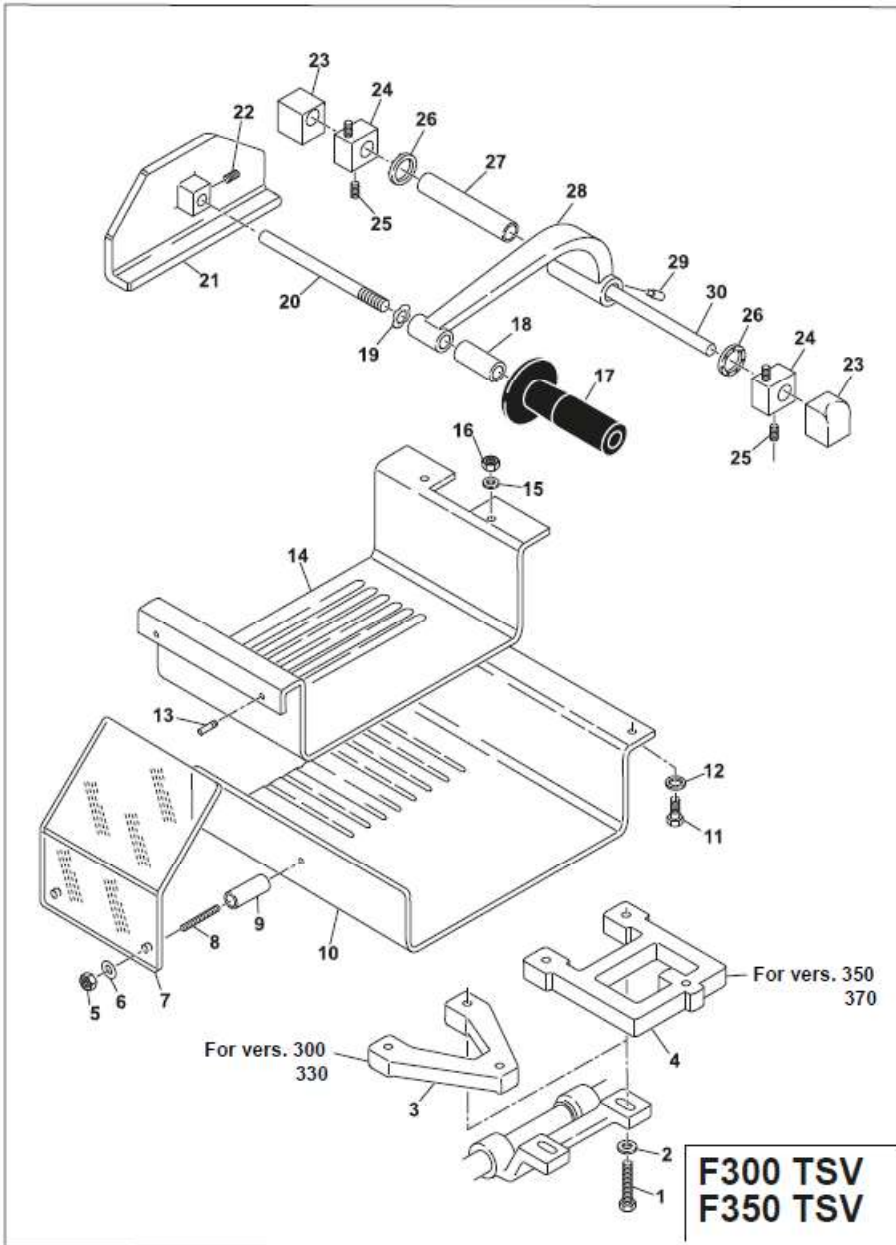

Unless otherwise defined at the moment of order, the machines are supplied together with the following:

- EC conformity declaration;
- instruction booklet for installation, use and maintenance.

## 2. TECHNICAL DESCRIPTION AND INTENDED CONDITIONS OF USE

### 2.1 General description

The slicer is mainly constituted by a footing which supports a circular blade mounted in an inclined position, driven by an electric motor, which has the function of slicing food products and by a carriage sliding on rails, placed under the abovementioned footing, which on its turn supports a carriage plate, parallel to the blade.

The slice thickness is adjustable thanks to a gauge plate placed before the blade; This plate, against which rests the product to be cut, can be moved transversely with respect to the blade by a value corresponding to the desired slice thickness.

The product is fed to the machine (towards the gauge plate) by weight (gravity).

All components of the machine are in aluminium alloy polished and anodically oxidized, varnished, in stainless steel and plastic material for food use. The cutting blade is driven by an electric motor and the motion transmission is obtained with a longitudinally grooved belt.

Start and stop are performed with a button provided with auxiliary circuit preventing accidental restarts after an outage. The machine incorporates (in some versions) a sharpener built for ease of use and safety.

### 2.2 Environmental conditions of the machine use

- Temperature...from -5 °C to + 40 °C (23 F to 104 F)
- Relative humidity ..... max 95%

### 2.3 Slicer correct use

The slicer is only designed to slice food of the type and within the dimensional limits indicated in this instruction booklet.

### 2.3.a Intended use (sliceable products)

The following products may be sliced:

- All types of cold cuts (raw and cooked ham, bacon).
- Boneless meat (cooked or raw at a temperature of not less than +3°C (37.4 F)).
- Bread and cheese (obviously the sliceable type such as Gruyère, Fontina, etc.).

### 2.3.b Unexpected or improper use (NOT sliceable products)

The following products CANNOT be sliced as they are liable to cause serious harm to the user and/or slicer itself:

- Frozen food.
- Deep-frozen food.
- Food with bones (meat and fish).
- All types of foods and vegetables
- Any other type of product specifically excluded product is sliceable but not intended to be eaten.

## 3. MECHANICAL SAFETY DEVICES AND ELECTRICAL PARTS

### WARNING

Do not tamper, remove nor bypass, under no circumstances, the safety devices installed on the equipment.

- Plastic or aluminium crankcase panel base protecting the electrical parts.
- Transparent handguard mounted on the product tray.
- Safety microswitch (excludes the chance of the motor activation if the blade plate has been removed).
- See the technical specifications chart.

### 3.1 Residual risks

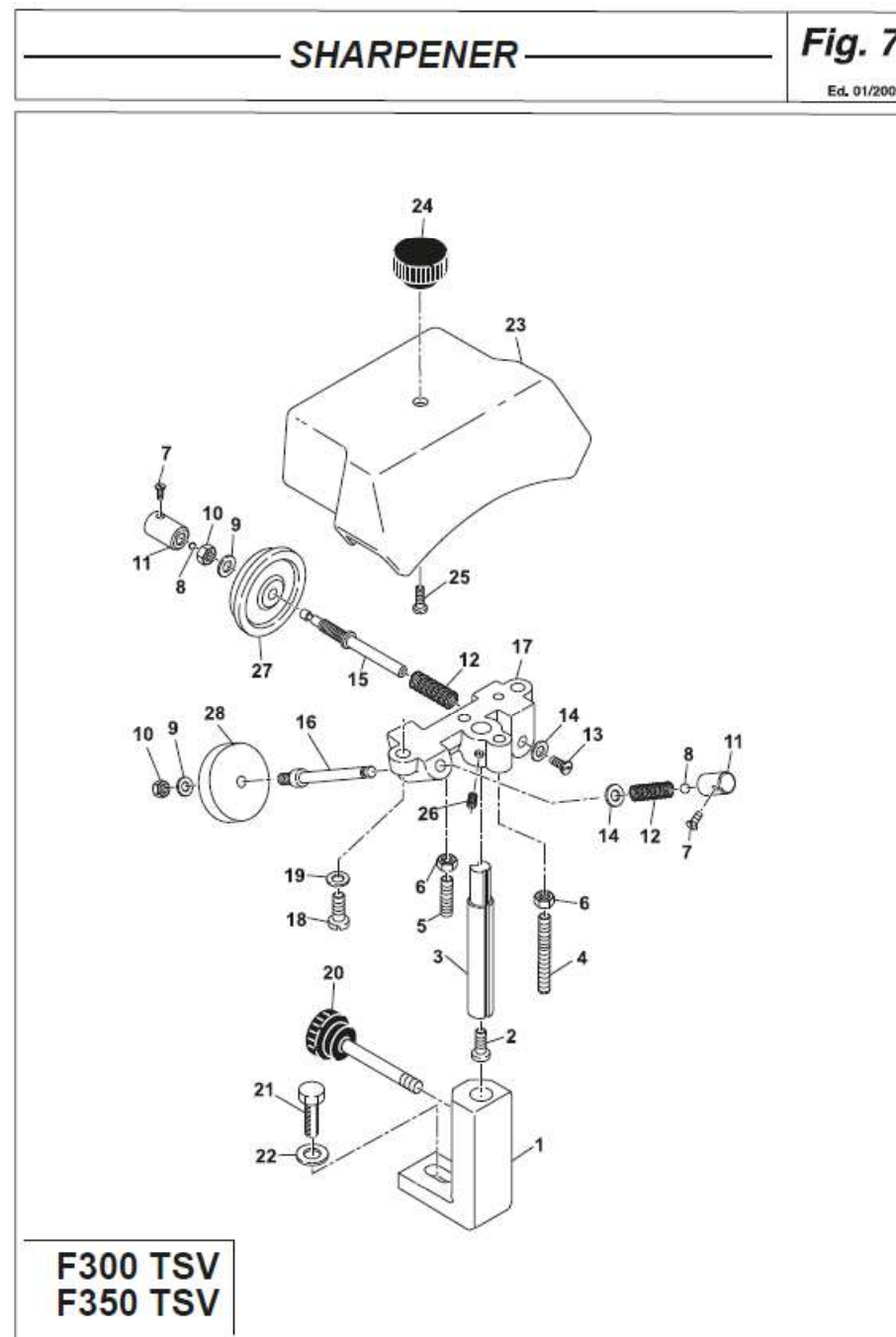

## ELECTRICAL PARTS

**Fig. 6**

Ed, 01/2009

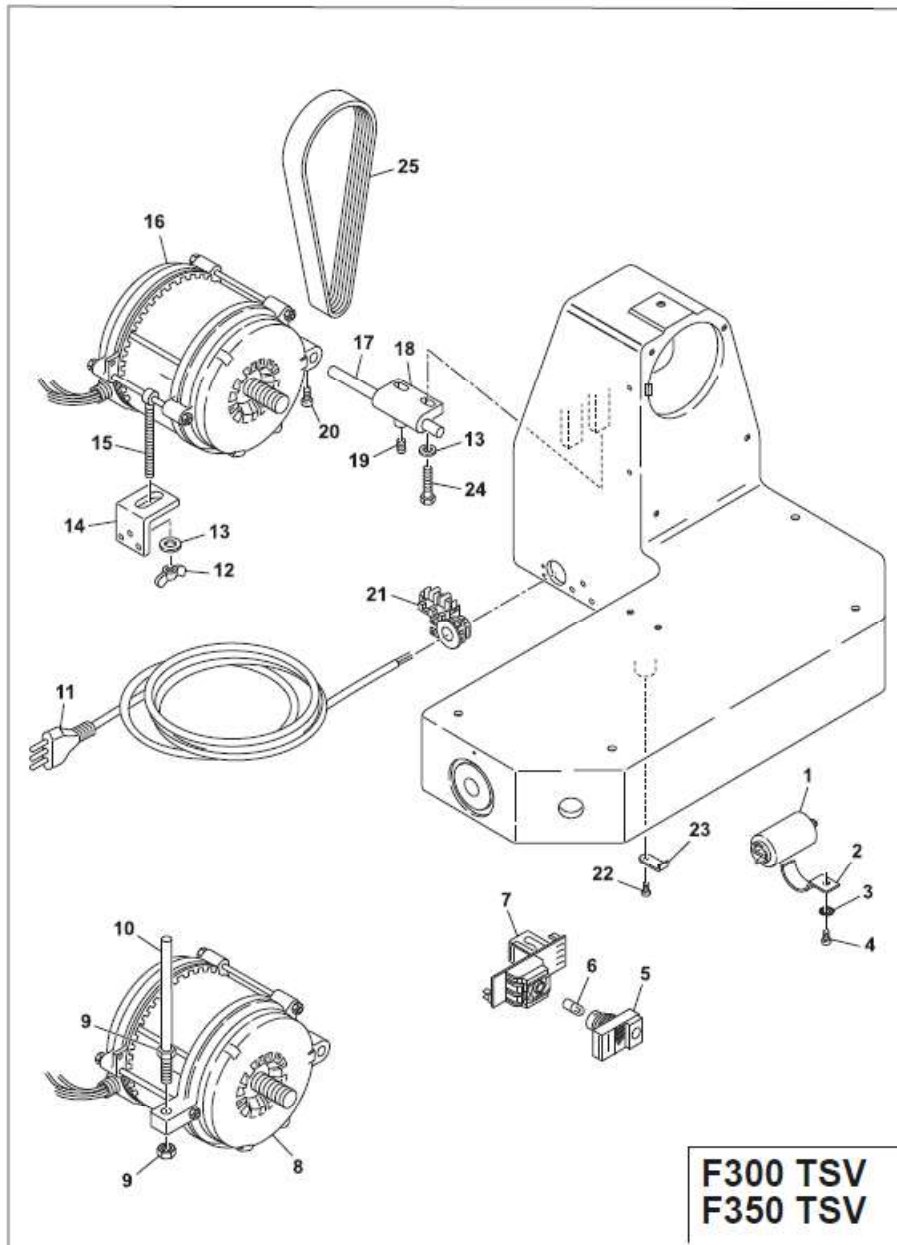

### WARNING

During slicer use, cleaning and maintenance operations, notwithstanding all the possible cautions taken during the design and the construction of the machine, residual risks (cutting) still exist during use or during cleaning or maintenance. Therefore be careful and **PAY THE UTMOST ATTENTION** to what you are doing. **DO NOT** use the machine if you are not in perfect psychological and physical conditions.

### Intermittent service

- **ONLY for "F 195" version)**

5 min. pause every 15/20 min. of work.

- All the other machines have a ventilated motor.

Supply voltage: Please see data plate on the machine base.

## TECHNICAL SPECIFICATIONS

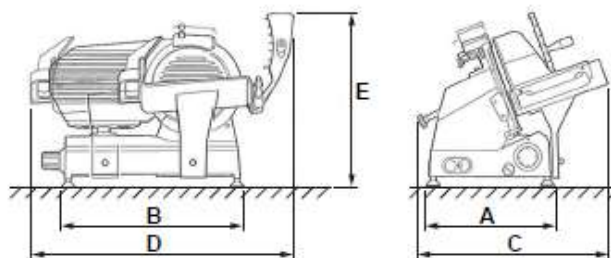

F 195 - S 220  
 F 250 ES - F 195 AF  
 S 220 AF - F 250 R  
 F 250 E - F 250 I - F 275 E  
 F 275 I - F 275 IL - F 300 R  
 SSI-12E - F 300 EL  
 F 300 CL - SSI-12I - F 330 I  
 SSI-14I - F 370 I

	F 195 *	S 220	F 250 ES	F 195 AF *	S 220 AF	F 250 R
A (mm)	255	280	290	255	280	280
B (mm)	345	415	440	345	415	415
C (mm)	360	405	425	360	405	405
D (mm)	520	580	620	520	580	580
E (mm)	315	340	370	315	340	370
Kg:	10	13,5	15,5	10	13,5	14
Single-phase motor: 115-220-240V~ 50/60Hz	0,20 Hp	0,25 Hp	0,30 Hp	0,20 Hp	0,25 Hp	0,25 Hp
Ø blade (mm):	195	220	250	195	220	250
Rpm:	300	300	300	300	300	300
Slice thickness (mm):	0÷15	0÷15	0÷16	0÷15	0÷15	0÷15
Working cut: L x H (mm):	140x140	190x160	220x190	140x140	190x160	190x190
Sharpener	not built-in	not built-in	not built-in	built-in	built-in	built-in
Micro EX CE	on request	on request	on request	on request	on request	on request
Micro CE DO	standard	standard	on request	standard	standard	standard
Base EX CE	on request	on request	on request	on request	on request	on request
Base CE DO	standard	standard	standard	standard	standard	standard
Handguard/finger guard EX CE	standard	standard	standard	standard	standard	standard
Handguard/finger guard CE DO	standard	standard	standard	standard	standard	standard

\* Not ventilated motor

## BLADE PLATE

**Fig. 5**

Ed. 01/2009

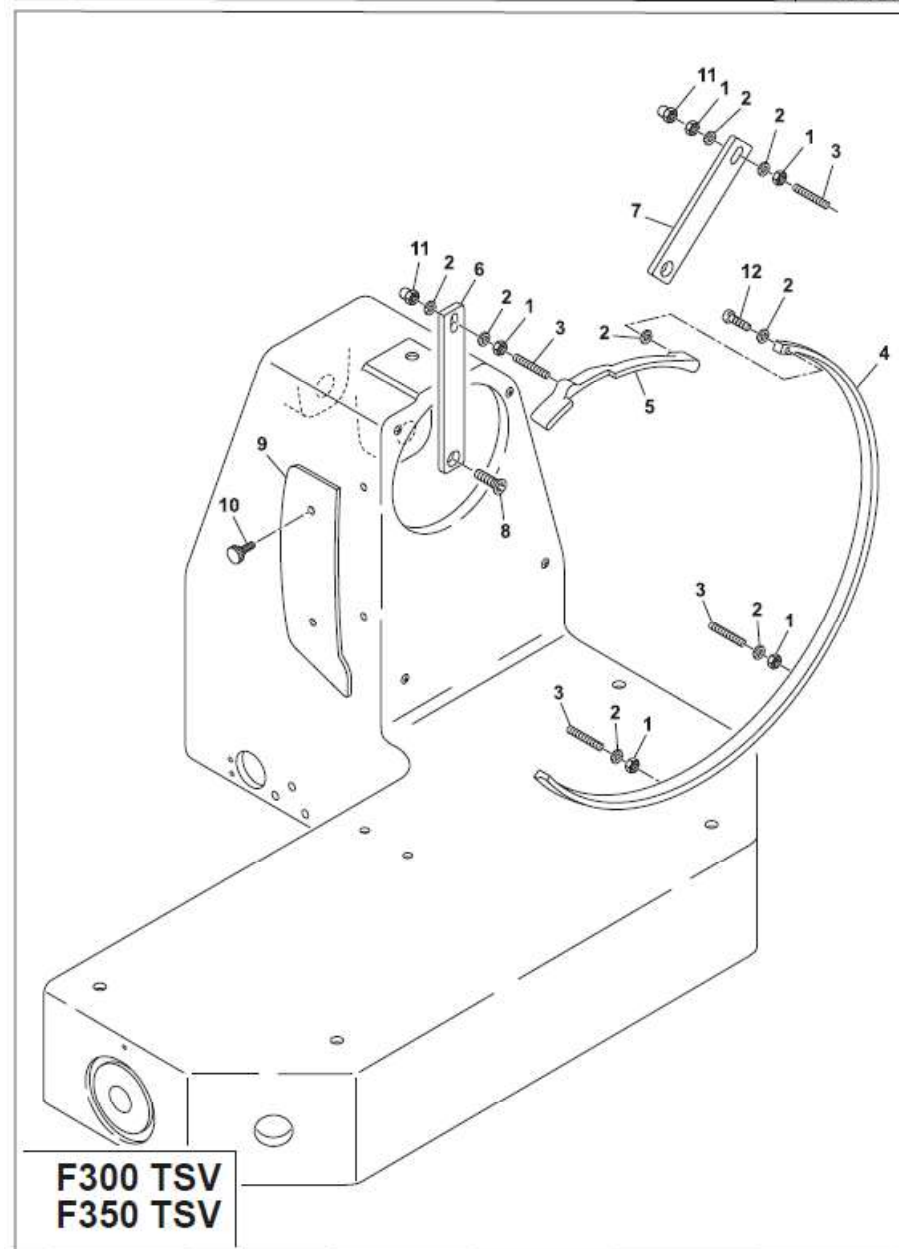

**F300 TSV  
 F350 TSV**

TECHNICAL SPECIFICATIONS

PRODUCT GRIP

Fig. 4

Ed. 01/2009

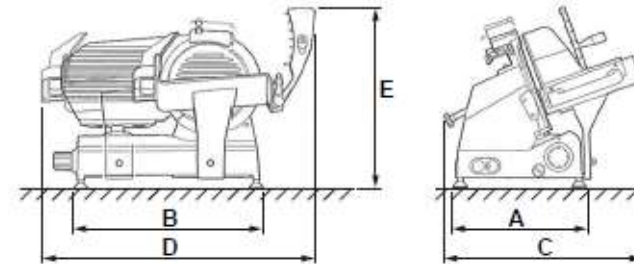
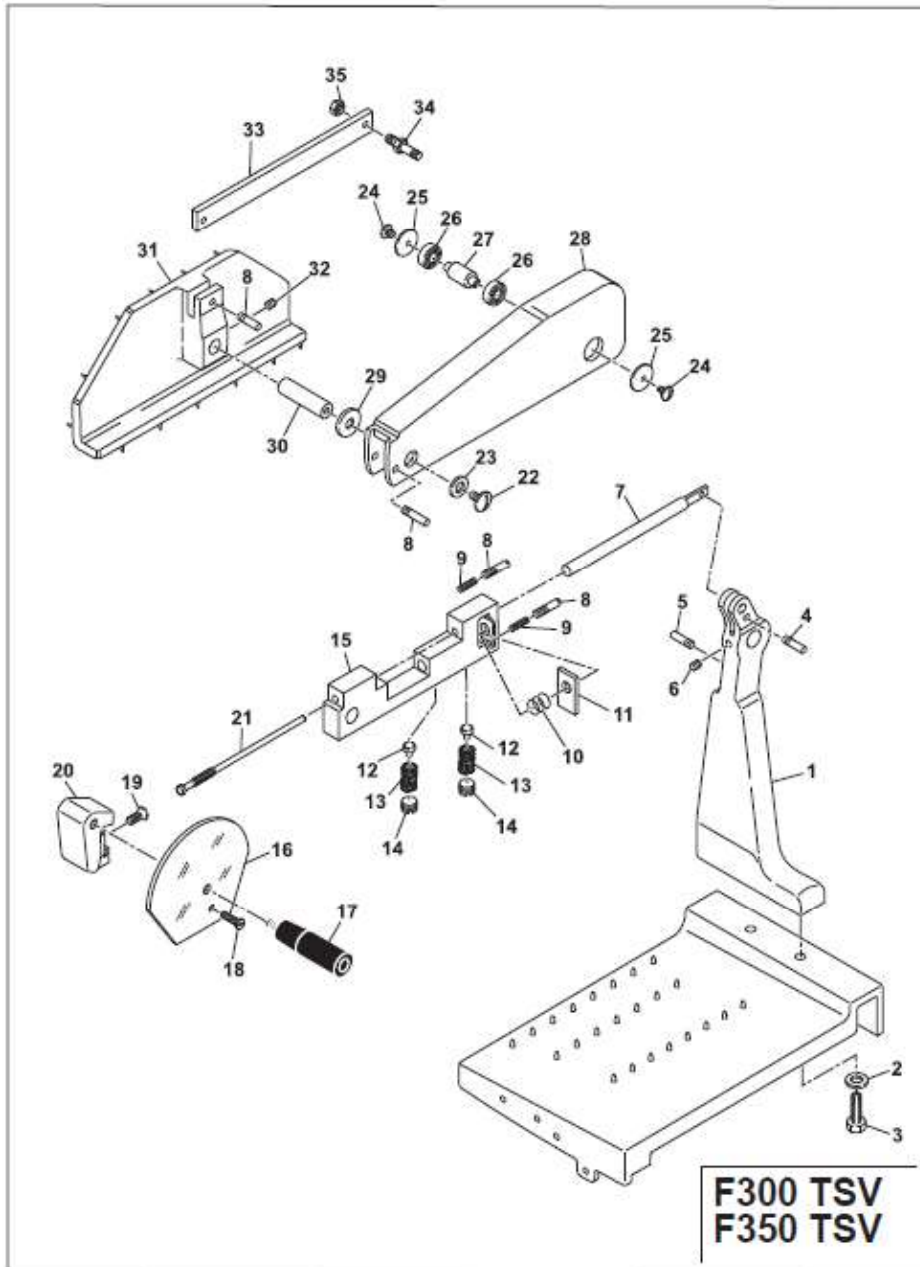

- F 195 - S 220
- F 250 ES - F 195 AF
- S 220 AF - F 250 R
- F 250 E - F 250 I - F 275 E
- F 275 I - F 275 IL - F 300 R
- SSI-12E - F 300 EL
- F 300 CL - SSI-12I - F 330 I
- SSI-14I - F 370 I

	F 250 E	F 250 I	F 275 E	F 275 I	F 275 IL	F 300 R
A (mm)	290	340	290	340	340	290
B (mm)	440	465	440	465	490	440
C (mm)	425	480	440	495	500	485
D (mm)	620	630	620	640	760	650
E (mm)	370	440	390	440	510	440
Kg:	15,5	21	16,5	22	24	19
Single-phase motor: 115-220-240V- 50/60Hz	0,30 Hp	0,35 Hp	0,30 Hp	0,35 Hp	0,35 Hp	0,33 Hp
Ø blade (mm):	250	250	275	275	275	300
Rpm:	300	300	300	300	300	300
Slice thickness (mm):	0÷16	0÷16	0÷16	0÷16	0÷16	0÷16
Working cut: L x H (mm)	220x190	220x190	220x220	210x210	260x215	220x210
Sharpener	built-in	built-in	built-in	built-in	built-in	built-in
Micro EX CE	on request	standard	on request	standard	standard	on request
Micro CE DO	standard	standard	standard	standard	standard	standard
Base EX CE	on request	on request	on request	on request	on request	on request
Base CE DO	standard	standard	standard	standard	standard	standard
Handguard/finger guard EX CE	standard	on request	standard	on request	on request	on request
Handguard/finger guard CE DO	standard	standard	standard	standard	standard	standard

## TECHNICAL SPECIFICATIONS

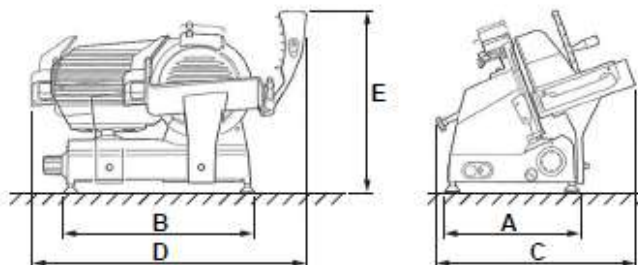

F 195 - S 220  
 F 250 ES - F 195 AF  
 S 220 AF - F 250 R  
 F 250 E - F 250 I - F 275 E  
 F 275 I - F 275 IL - F 300 R  
 SSI-12E - F 300 EL  
 F 300 CL - SSI-12I - F 330 I  
 SSI-14I - F 370 I

	SSI-12E	F 300 EL	F 300 CL	SSI-12I	F 330 I	SSI-14I
A (mm)	340	340	350	410	410	415
B (mm)	465	490	570	530	530	580
C (mm)	495	500	560	540	550	585
D (mm)	650	760	870	770	770	890
E (mm)	440	510	500	465	465	480
Kg:	23	25	27,5	30	32	36
Single-phase motor: 115-220-240V~ 50/60Hz	0,35 Hp	0,35 Hp	0,35 Hp	0,50 Hp	0,50 Hp	0,50 Hp
Ø blade (mm):	300	300	300	300	330	350
Rpm (rpm):	300	300	300	280	280	260
Slice thickness (mm):	0÷16	0÷16	0÷16	0÷16	0÷16	0÷16
Working cut: L x H (mm)	220x220	260x230	300x220	260x220	260x235	310x260
Sharpener	built-in	built-in	built-in	built-in	built-in	built-in
Micro EX CE	standard	standard	standard	standard	on request	on request
Micro CE DO	standard	standard	standard	standard	on request	on request
Base EX CE	on request	on request	on request	on request	on request	on request
Base CE DO	standard	standard	standard	standard	standard	standard
Handguard/finger guard EX CE	on request	on request	on request	on request	on request	on request
Handguard/finger guard CE DO	standard	standard	standard	standard	standard	standard

## BLADE

**Fig. 3**

Ed. 01/2009

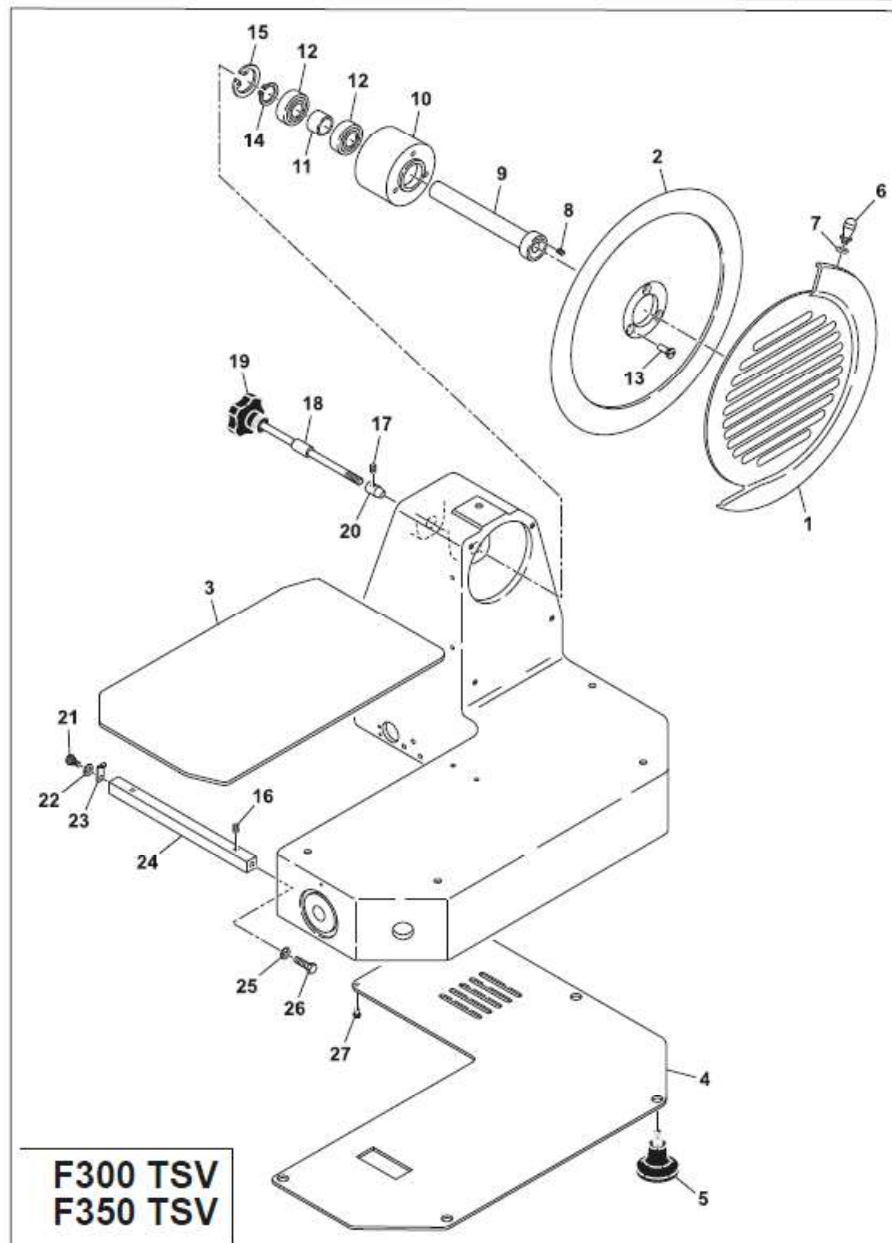

# GUIDES

**Fig. 2**

Ed. 01/2009

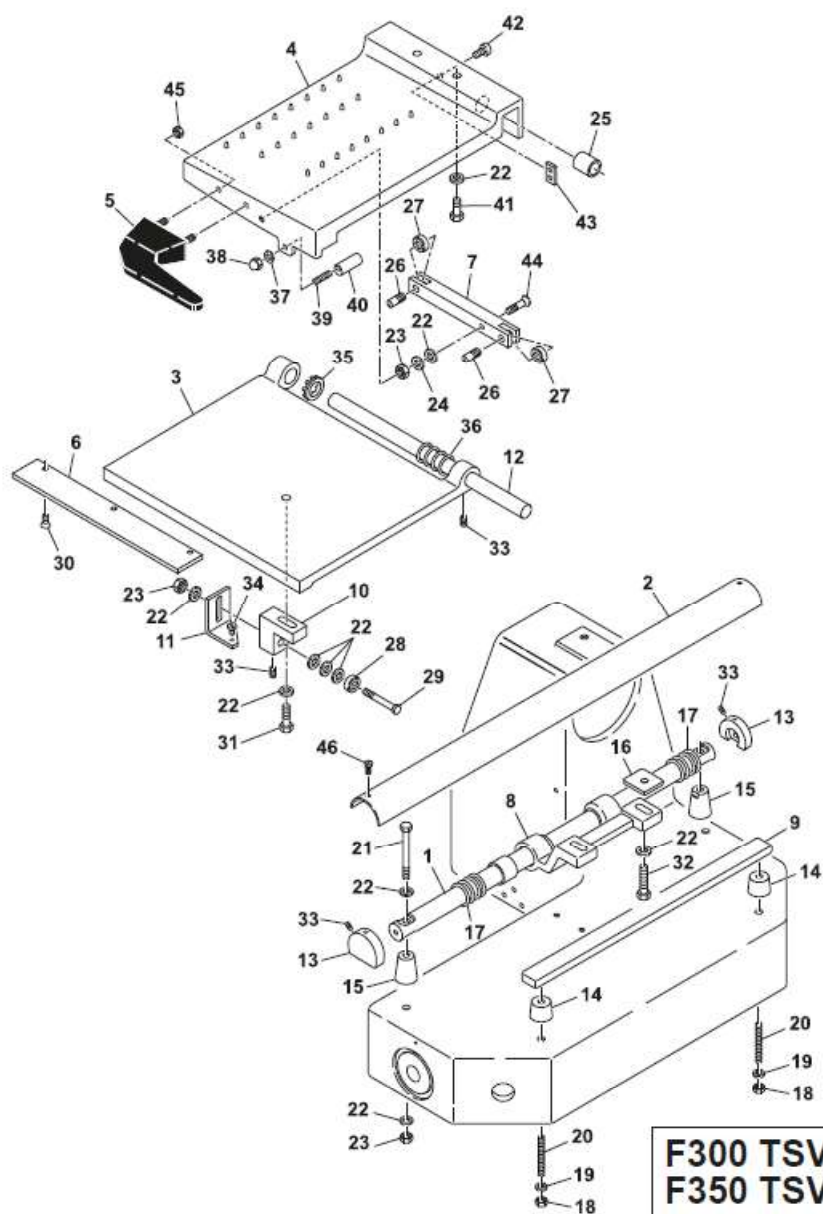

## TECHNICAL SPECIFICATIONS

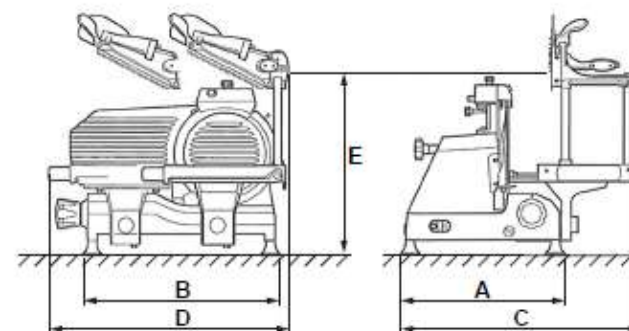

F 250 TSV - F 250 TCV  
 F 300 TSV R  
 F 300 TCV R - F 300 TSV  
 F 300 TCV - F 330 TSV  
 F 330 TCV - F 350 TSV  
 F 350TCV - F 370 TSV  
 F 370 TCV

	F 370 I	F 250 TSV	F 250 TCV	F 300 TSVR	F 300 TCVR	F 300 TSV
A (mm)	415	360	360	360	360	420
B (mm)	580	460	460	460	460	530
C (mm)	585	520	520	520	520	550
D (mm)	890	610	610	610	610	710
E (mm)	480	515	500	515	500	610
Kg:	37	25	21	27	24	36
Single-phase motor: 115-220-240V~ 50/60Hz	0,50 Hp	0,35 Hp	0,35 Hp	0,35 Hp	0,35 Hp	0,50 Hp
Ø blade (mm):	370	250	250	300	300	300
Rpm (rpm):	260	300	300	300	280	280
Slice thickness (mm):	0÷16	0÷16	0÷16	0÷16	0÷16	0÷16
Working cut: L x H (mm)	300x275	260x190	215x170	260x210	215x210	260x200
Sharpener	built-in	built-in	built-in	built-in	built-in	built-in
Micro EX CE	on request	standard	standard	standard	standard	standard
Micro CE DO	on request	standard	standard	standard	standard	standard
Base EX CE	on request	on request	on request	on request	on request	on request
Base CE DO	standard	standard	standard	standard	standard	standard
Handguard/finger guard EX CE	on request	standard	on request	standard	on request	standard
Handguard/finger guard CE DO	standard	standard	standard	standard	standard	standard

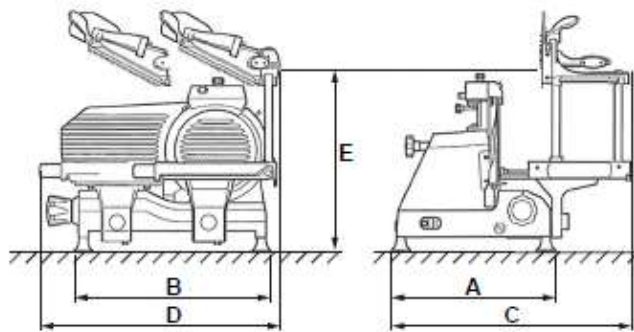

F 250 TSV - F 250 TCV  
 F 300 TSV R  
 F 300 TCV R - F 300 TSV  
 F 300 TCV - F 330 TSV  
 F 330 TCV - F 350 TSV  
 F 350 TCV - F 370 TSV  
 F 370 TCV

	F 300 TCV	F 330 TSV	F 330 TCV	F 350 TSV	F 350 TCV	F 370 TSV
A (mm)	420	420	420	530	530	530
B (mm)	530	530	530	650	650	650
C (mm)	550	550	550	650	670	650
D (mm)	710	710	710	820	820	820
E (mm)	550	610	550	640	640	640
Kg:	34	37	35	45	43	46
Single-phase motor: 115-220-240V~ 50/60Hz	0,50 Hp	0,50 Hp	0,50 Hp	0,50 Hp	0,50 Hp	0,50 Hp
Ø blade (mm):	300	330	330	350	350	370
Rpm (rpm):	280	260	260	260	260	260
Slice thickness (mm):	0÷16	0÷16	0÷16	0÷16	0÷16	0÷16
Working cut: L x H (mm)	260x200	250x210	250x210	300x265	300x250	290x275
Sharpener	built-in	built-in	built-in	built-in	built-in	built-in
Micro EX CE	standard	on request	on request	on request	on request	on request
Micro CE DO	standard	on request	on request	on request	on request	on request
Base EX CE	on request	on request	on request	on request	on request	on request
Base CE DO	standard	standard	standard	standard	standard	standard
Handguard/finger guard EX CE	standard	standard	standard	standard	standard	standard
Handguard/finger guard CE DO	standard	standard	standard	standard	standard	standard

BASE

Fig. 1

Ed. 01/2009

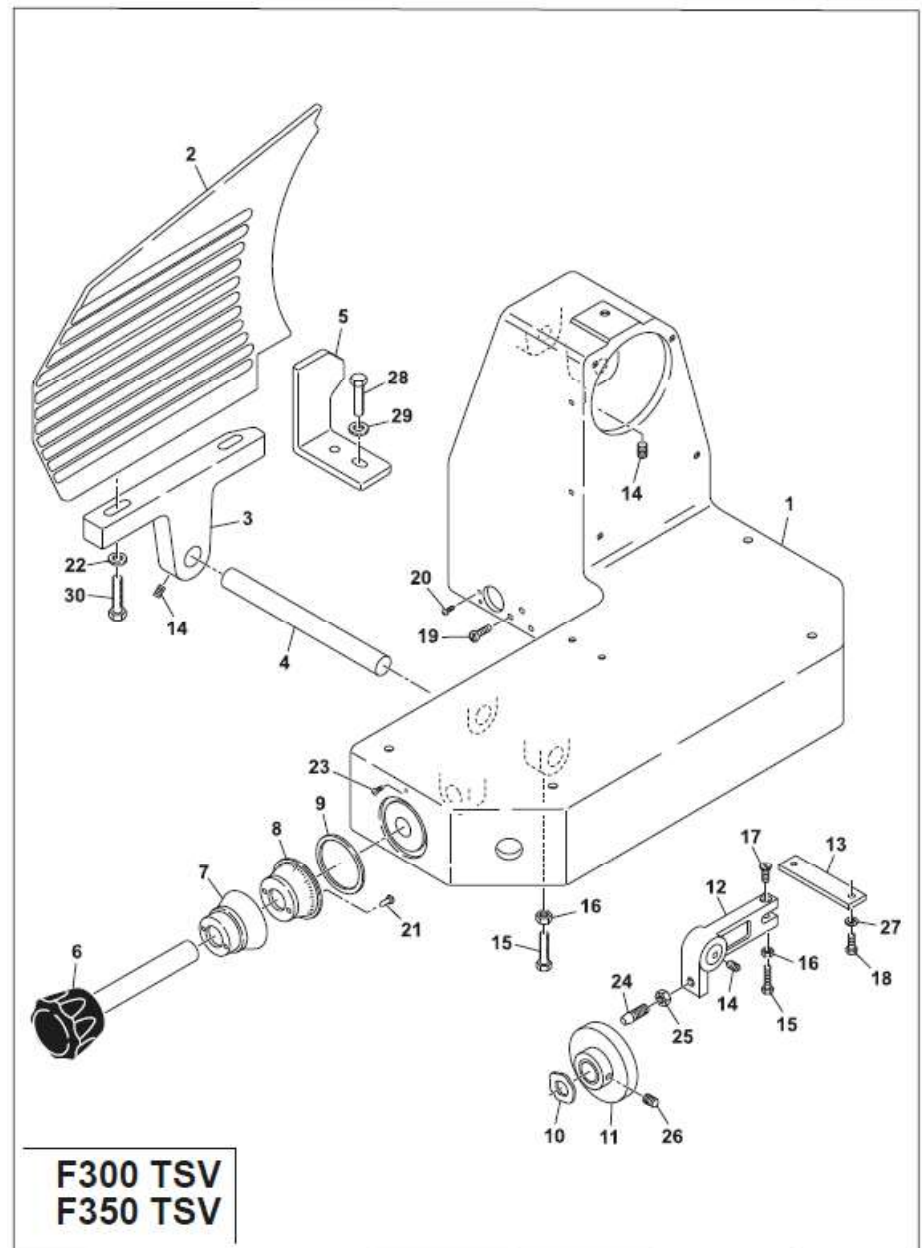

F300 TSV  
 F350 TSV

TECHNICAL SPECIFICATIONS

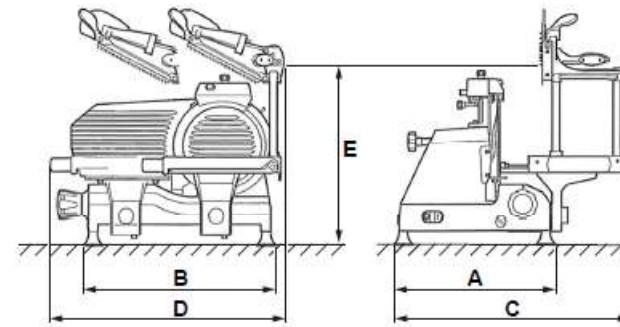
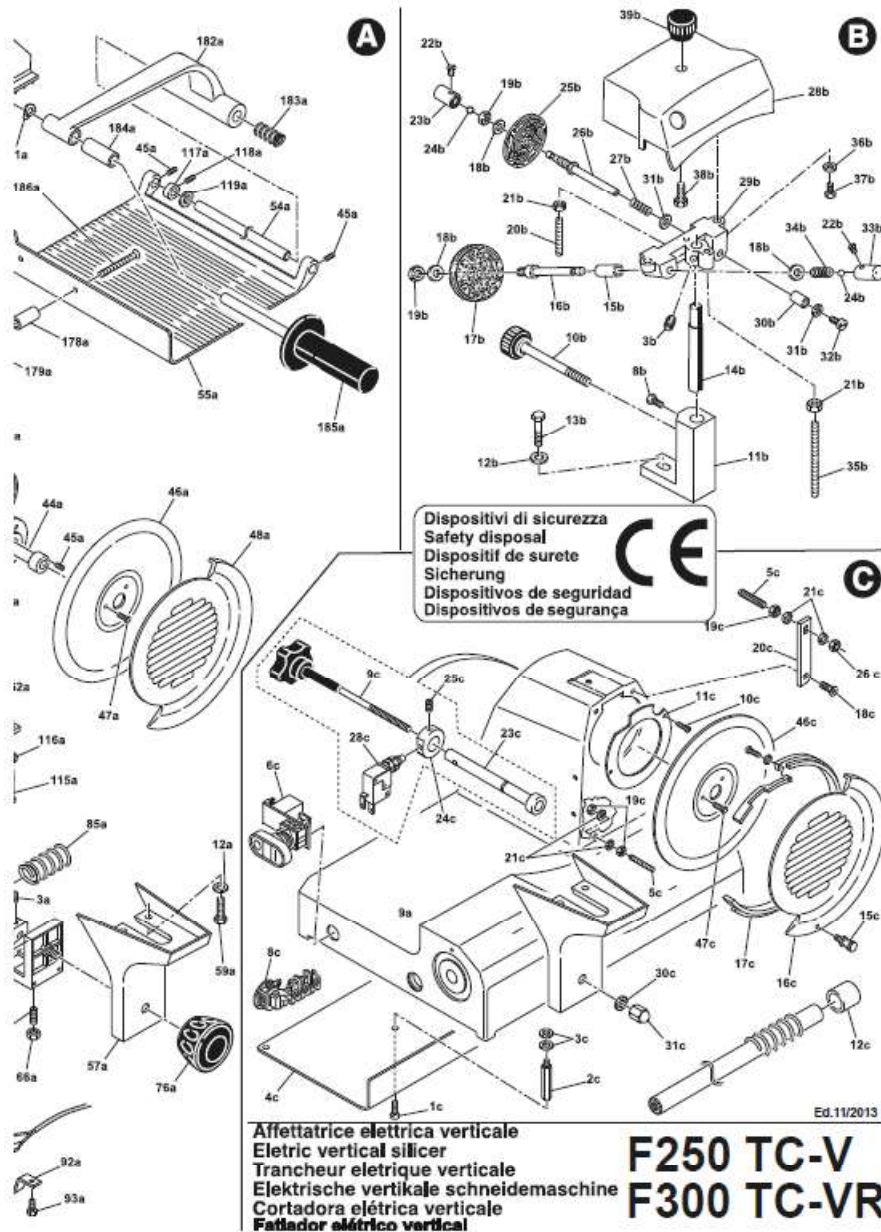

F 250 TSV - F 250 TCV  
F 300 TSV R  
F 300 TCV R - F 300 TSV  
F 300 TCV - F 330 TSV  
F 330 TCV - F 350 TSV  
F 350TCV - F 370 TSV  
F 370 TCV

	F 370 TCV				
A (mm)	530				
B (mm)	650				
C (mm)	670				
D (mm)	820				
E (mm)	640				
Kg:	44				
Single-phase motor:	0,50 Hp				
	115-220-240V~ 50/60Hz				
Ø blade (mm):	370				
Rpm (rpm):	260				
Slice thickness (mm):	0÷16				
Working cut: L x H (mm)	290x260				
Sharpener	built-in				
Micro EX CE	on request				
Micro CE DO	on request				
Base EX CE	on request				
Base CE DO	standard				
Handguard/finger guard EX CE	standard				
Handguard/finger guard CE DO	standard				

MAIN COMPONENTS

Figure 03

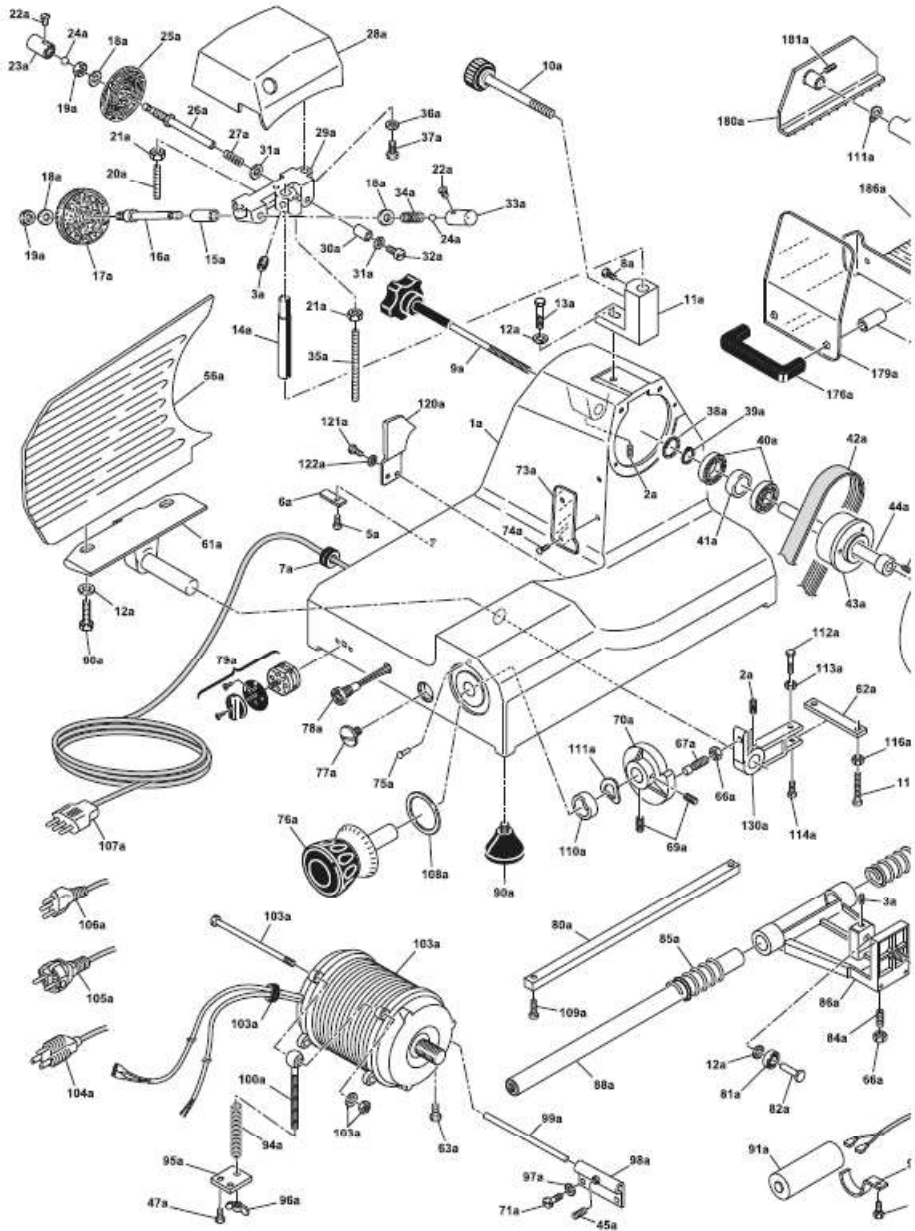
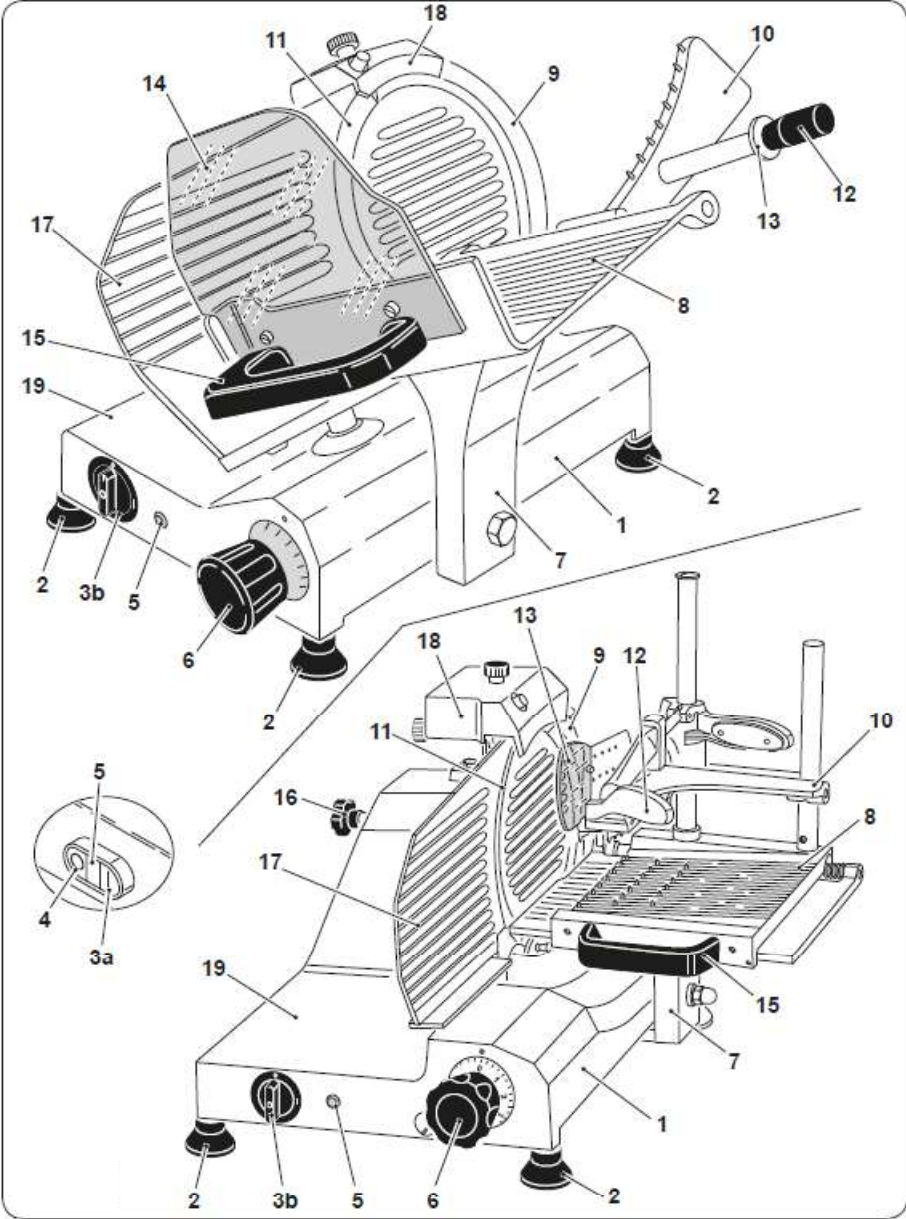

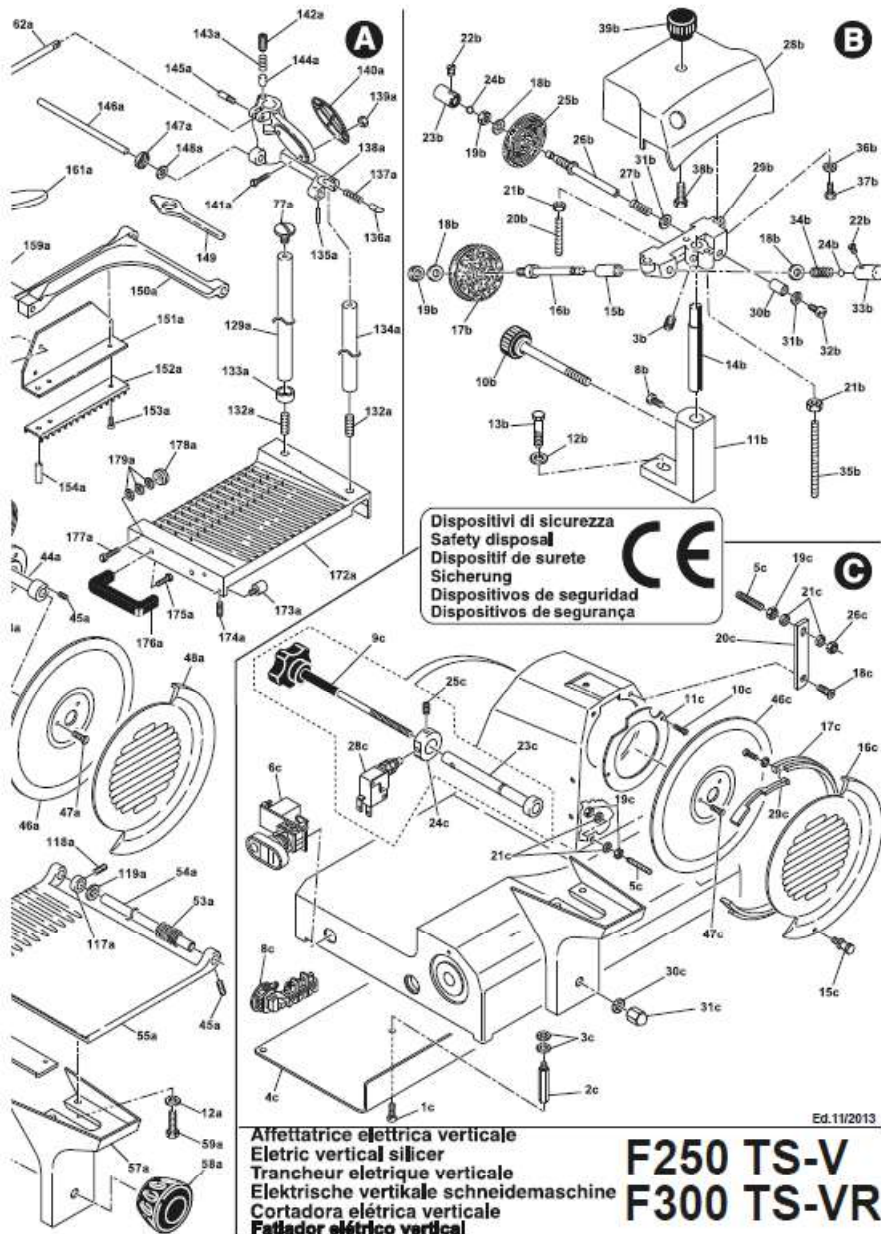

1. Base
2. Adjustable feet
- 3a. Startup button "I"
- 3b. Switch "0/I"
4. "STOP" "0" button
5. Machine running warning light
6. Slice thickness control knob
7. Carriage tray support
8. Sliding product tray
9. Blade plate
10. Product grip
11. Blade
12. Product grip handle
13. Product grip handguard
14. Tray handguard protection
15. Product tray handle
16. Blade plate tie-rod
17. Gauge plate
18. Sharpener
19. Collector surface
20. Slice guard
21. Supply cord
22. Nameplate

Figure 04

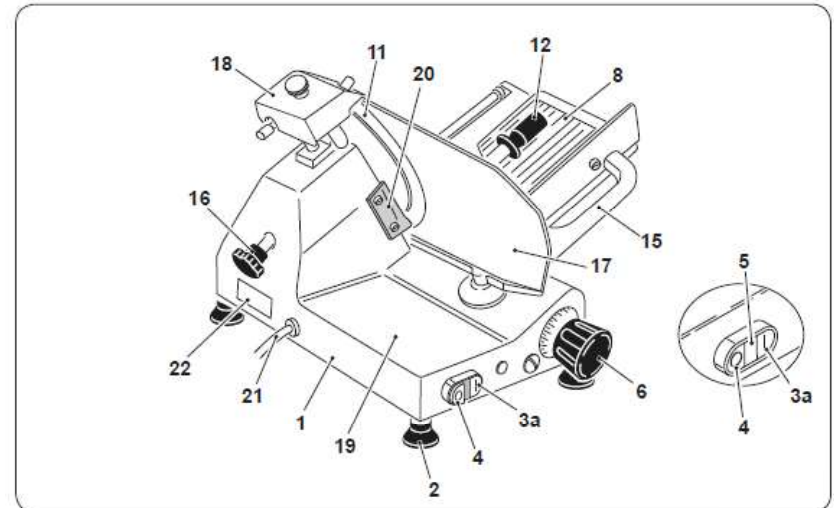

For possible "Spare parts" orders do NOT consider the numbering in this booklet, please refer to the "Spare parts" exploded view drawing only.

#### 4. INSTALLATION AND PRELIMINARY CHECKS

##### 4.1 - Installation

Place the slicer on a well leveled, smooth, dry and stable plane, suitable to support its weight.

##### 4.2 - Electric connection

Install the slicer in the immediate vicinity of an outlet in compliance with EC standards derived from a system that complies with applicable regulations.

It is the user's responsibility to verify the suitability and proper functioning of the electrical system (supply line, outlet, distribution panel, differential magnetothermal circuit breaker protection, grounding system).

Before executing the connection check that the characteristics of the power supply network correspond to those indicated on the nameplate of the slicer.

### 4.3 - Control of operation and blade rotation direction

- Depending on the model, press the green button “I” (3a) or turn the switch (3b) clockwise on “I/ ON” to start the blade.
- The warning light (5) lights up indicating that the machine works correctly.
- Depending on the model, press the red button “0” (4) or turn the switch (3b) anticlockwise on “0/ OFF” to stop the blade movement.
- Check that the blade rotates towards the direction indicated by the arrow (anticlockwise if looking at the machine from the blade plate side).

Figure 05

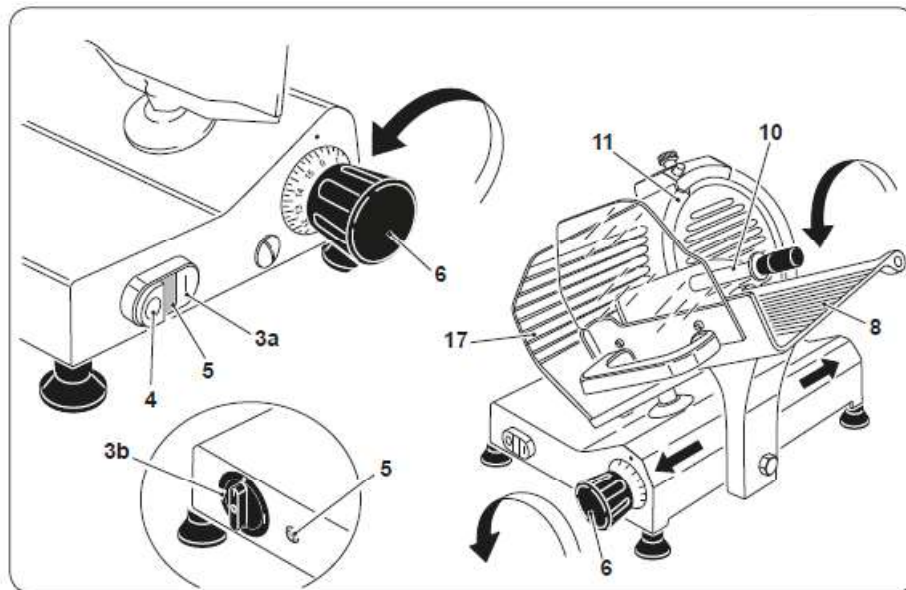

- Three-phase supply slicer:  
if the blade (11) rotates in the opposite direction, immediately stop the machine by pressing the “0” button (4) or by turning the switch (3b) anticlockwise on “0/OFF” (depending on the model) and request the intervention of qualified personnel to invert the two power cables inside the plug.
- Check the product tray (8) and the product grip (10) smoothness.
- Check the control knob (6) and the gauge plate (17) functioning and adjustment.
- The slices thickness is adjustable by turning the knob (6), with a graduated scale, anticlockwise.

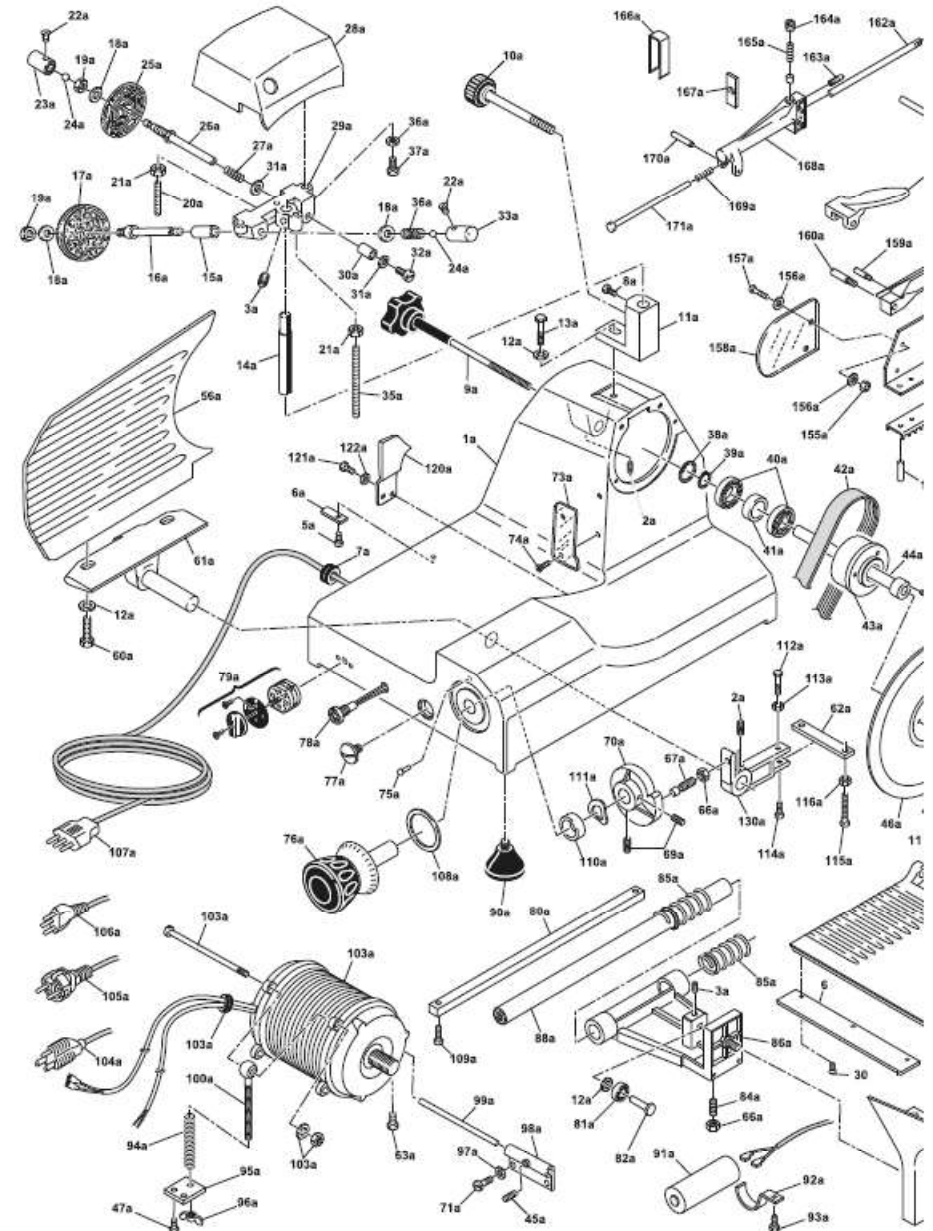

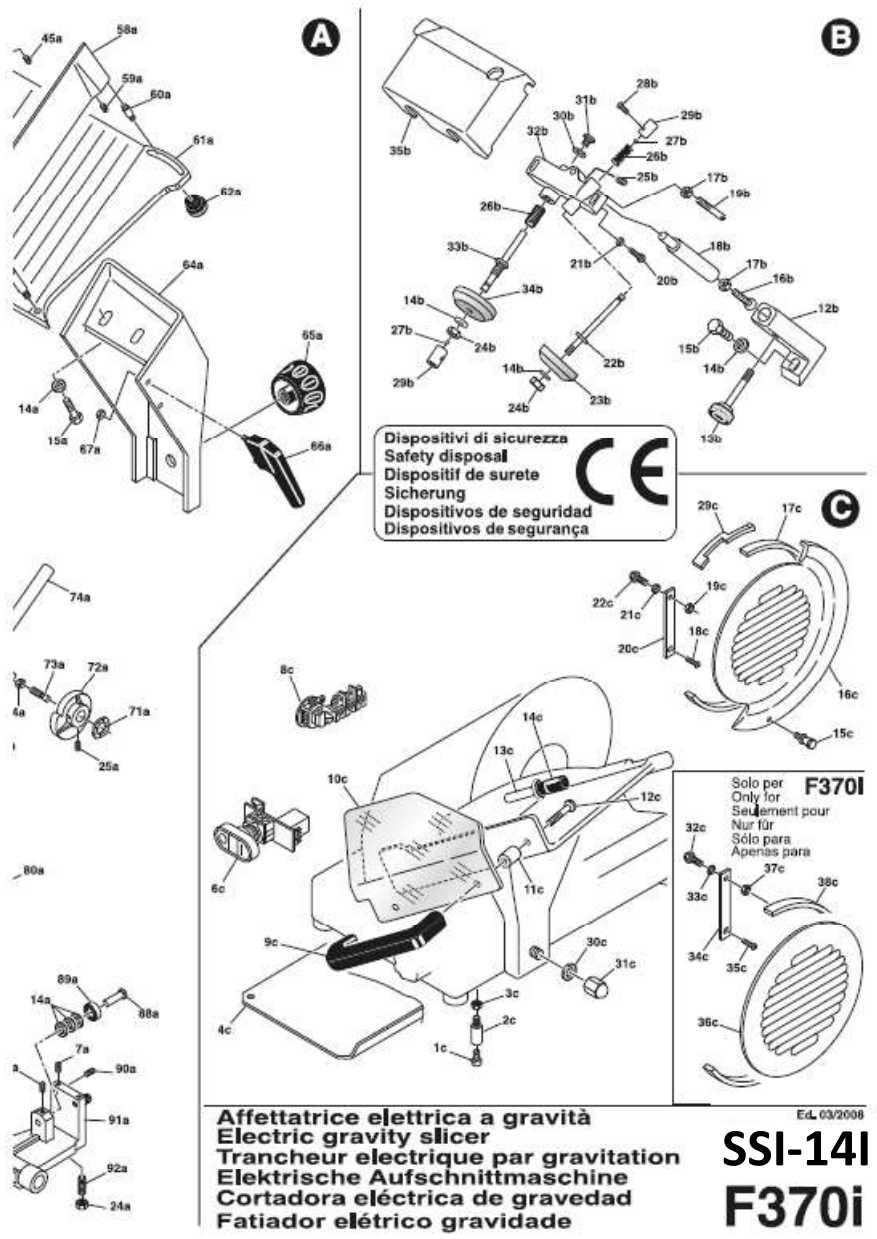

## 5. USING THE MACHINE

### 5.1 Loading the product on the tray

- Check that the slice thickness control knob (6) is correctly placed on "0".
- Draw the tray back completely (towards the operator) to loading position.
- Lift the product grip (10) by pulling it away by 10 cm from the blade and put it in rest position.
- Lay the product to be sliced on the tray (8) against the wall on the operator **side**;
- Secure by means of the product grip (10) by exerting a slight pressure; such as to not allow the product to move during the cutting operation.

### 5.2 Slicing the products

- Adjust the slice thickness with the knob (6).
- Start the blade by pressing on the green button "I" (3a) or by turning the switch (3b) clockwise on "I/ON" (the indicator "5" turns on).
- Grip the handle (15) fixed to the tray (8) and start the forward and backward cutting movement.
- At the end of the cutting operations move the slice thickness control knob (6) back to "0" and draw the tray (8) back.
- Stop the blade movement by pressing the red button "0" (4) or by turning the switch (3b) anticlockwise on "0/OFF"; the warning light (5) turns off.

Figure 06

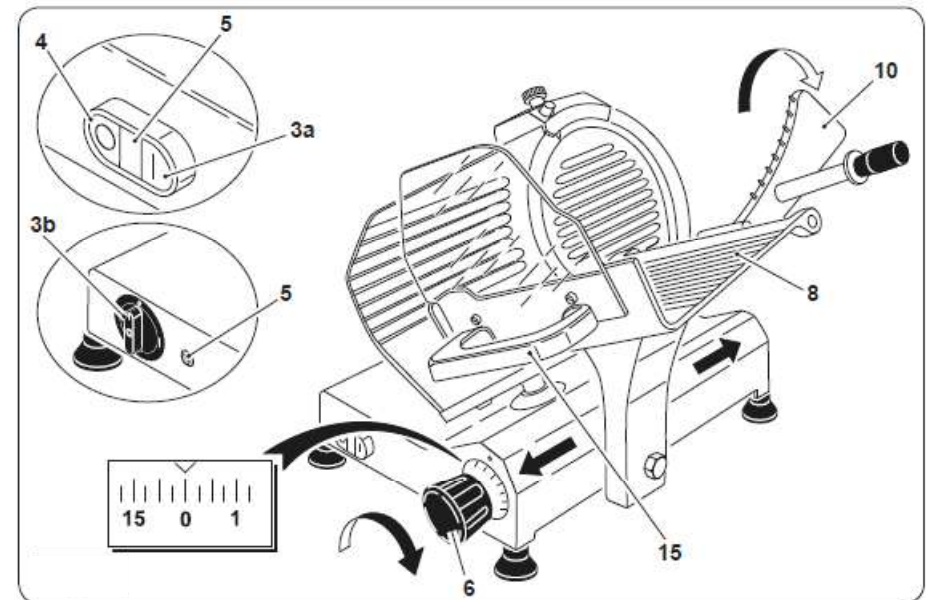

## 6. CLEANING THE SLICER

- When the processing is over, remove the waste residuals from the collector surface (19).

The machines must be accurately cleaned after use. After a shorter or longer period of inactivity clean the slicer before use.

### WARNING

**Cutting hazard! Use protective cut- and tear-resistant gloves and perform all operations with extreme care.**

#### 6.1 - Components disassembly

- Disconnect the plug from the mains power supply.
- Move the gauge plate control knob (6) to "0".
- Remove the various components as described in the following paragraphs.
- Fully unscrew (anticlockwise direction of rotation) the blade plate tie-rod (16).
- If the blade plate (9) is blocked, apply pressure on the tie-rod knob (16) to move it.
- Remove the tie rod (16) and remove the blade plate.
- Remove the slice guard (20) by unscrewing the two fixing screws.

Figure 07

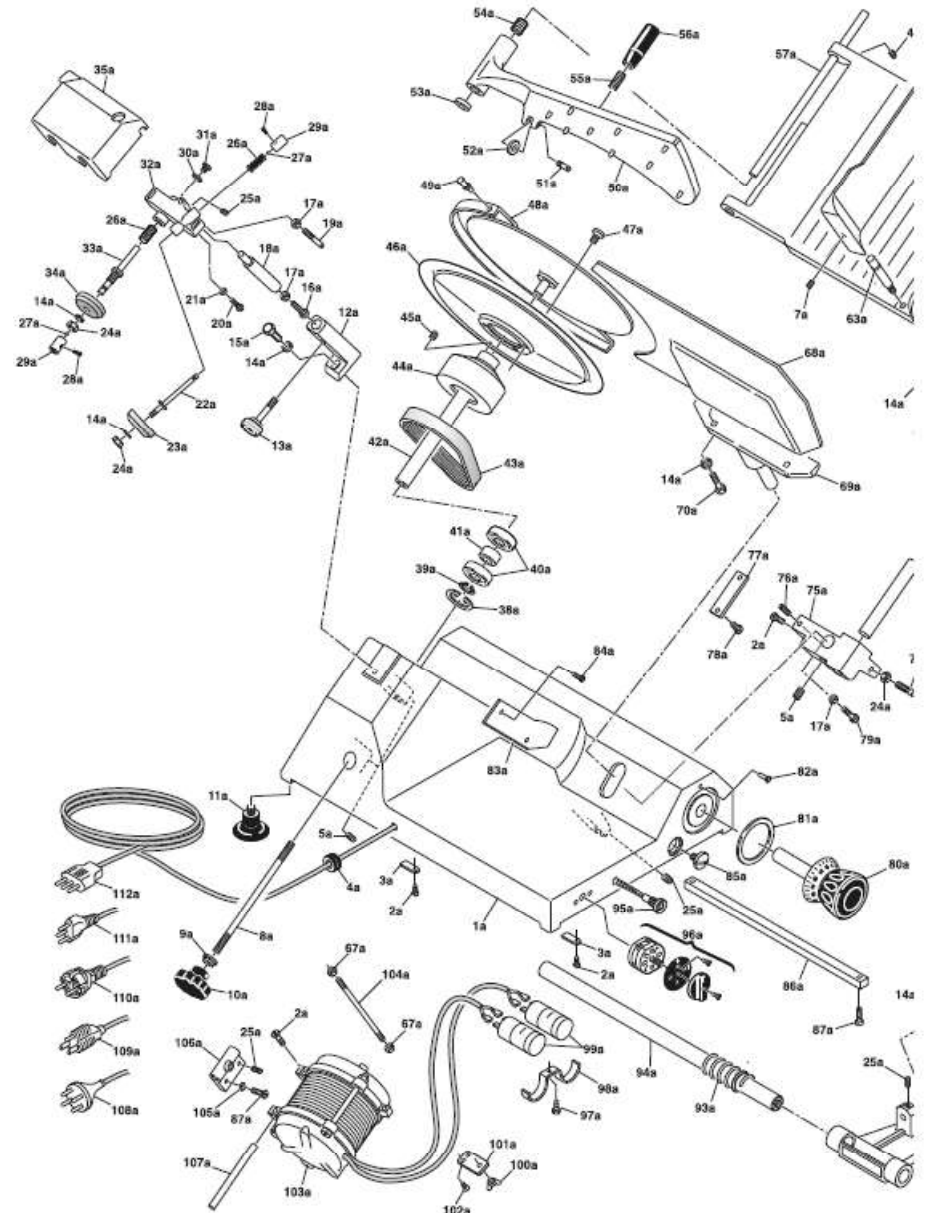
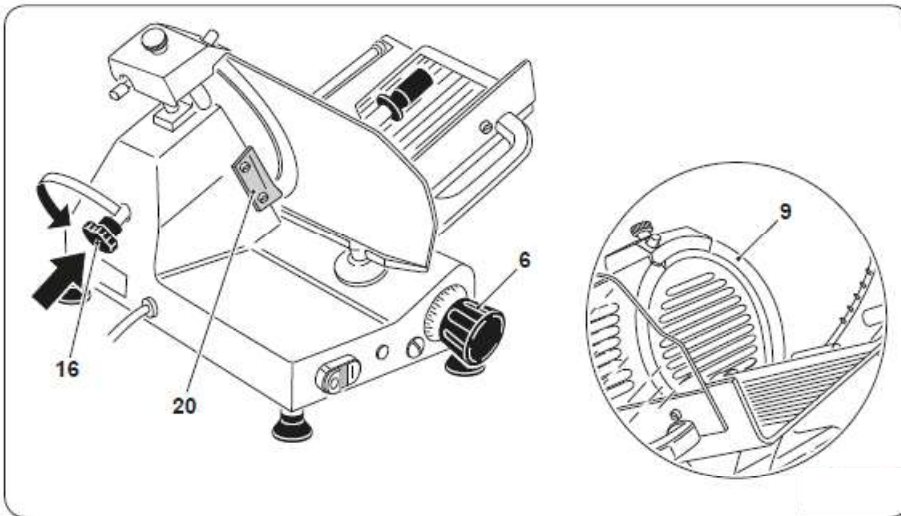

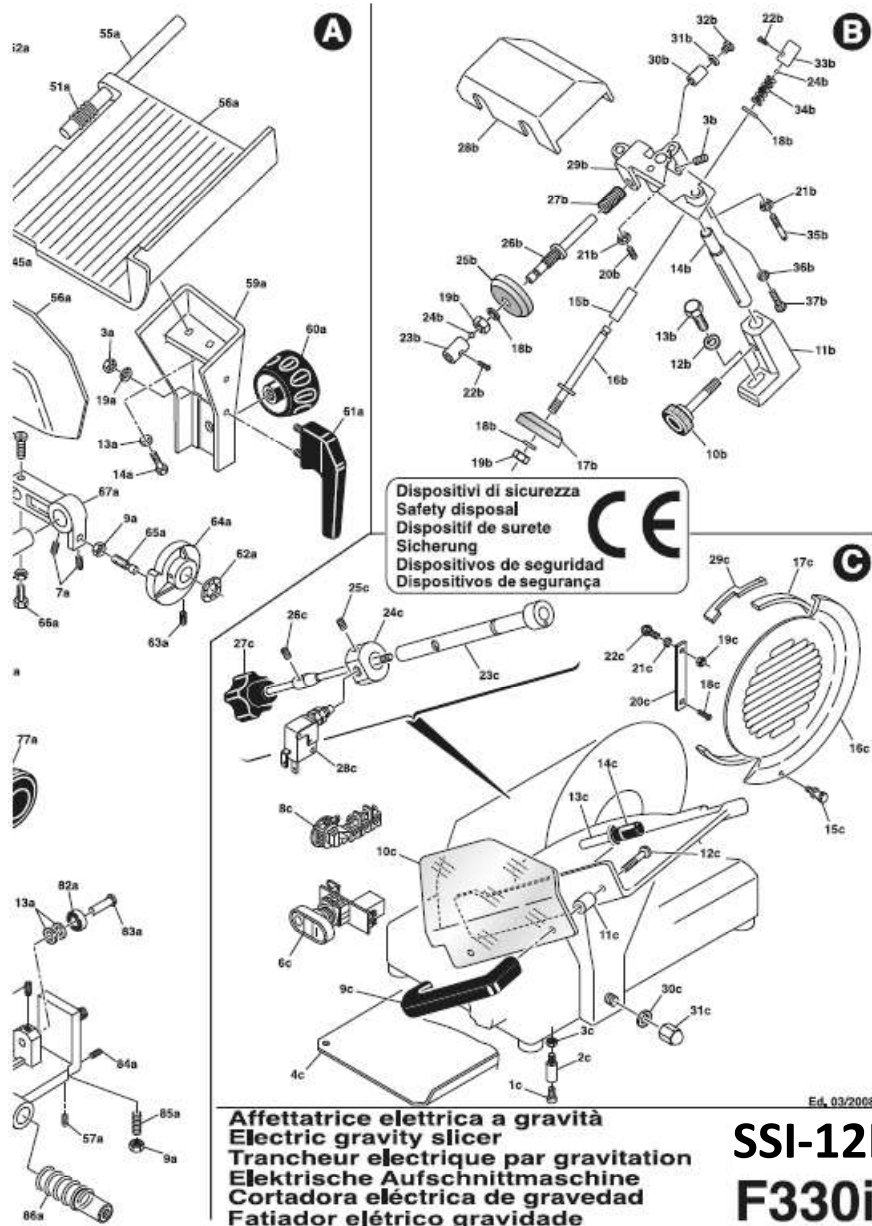

#### “EXTRA CE” version

- The product tray (8) can be easily removed by unscrewing the corresponding support (7) placed under it and by moving everything outward. This way, a perfect cleaning of this particular can be possible too.

#### “CE HOUSEHOLD USE” version

- The machines are equipped with a irremovable cap nut, as requested by the European standard. For this reason, it is not possible to manually disassemble the product tray (8).

#### WARNING

For the machine's body and blade cleaning use only a cloth dampened in water or alcohol and a biodegradable frothy dishwasher cleanser at pH 7-8, at a temperature at least of +30°C (86 F). Do not clean the machine with water or vapour jets or similar methods.

#### WARNING

Do not use alcohol based aggressive cleansers.

#### WARNING

Do not use corrosive cleansers.

#### WARNING

Do not wash in the dishwasher.

#### 6.2 - Base cleaning

After removing the components like it's described in the previous pages:

- Clean all the disassembled parts and the machine body using exclusively hot water (at a temperature of at least 30°C (86 F)) and a biodegradable frothy dishwasher cleanser (at pH 7-8).
- Use a soft, spongy cloth and, possibly, a nylon brush for the tray (8) and the product grip (10) sharp zones.
- Rinse exclusively with hot water and dry with soft and spongy cloths.

### 6.3 - Cleaning the blade

- Press on the blade with a wet cloth (11) slowly rubbing moving from the inside to the outside (towards the gauge plate “17”).

**WARNING**  
ALWAYS perform the blade cleaning (11) when the gauge plate (17) is close to the blade in safety position.

Figure 08

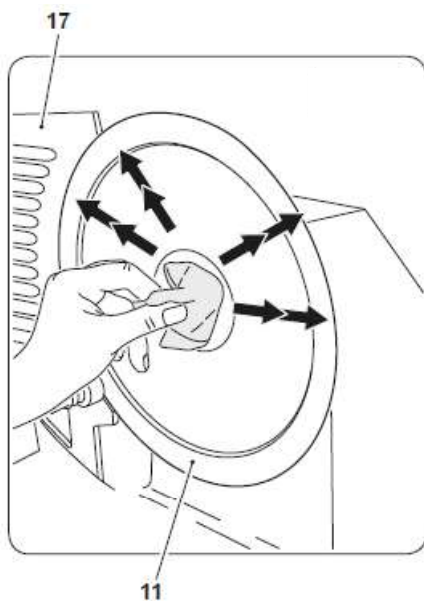

### 6.4 - Reassembling the machine

- Proceed in the opposite direction to what is indicated in the previous operations.
- To cover the slicer with a sheet to protect it from dust is advised.  
If you do not intend to use the slicer for some days, store it in a dry and covered place.

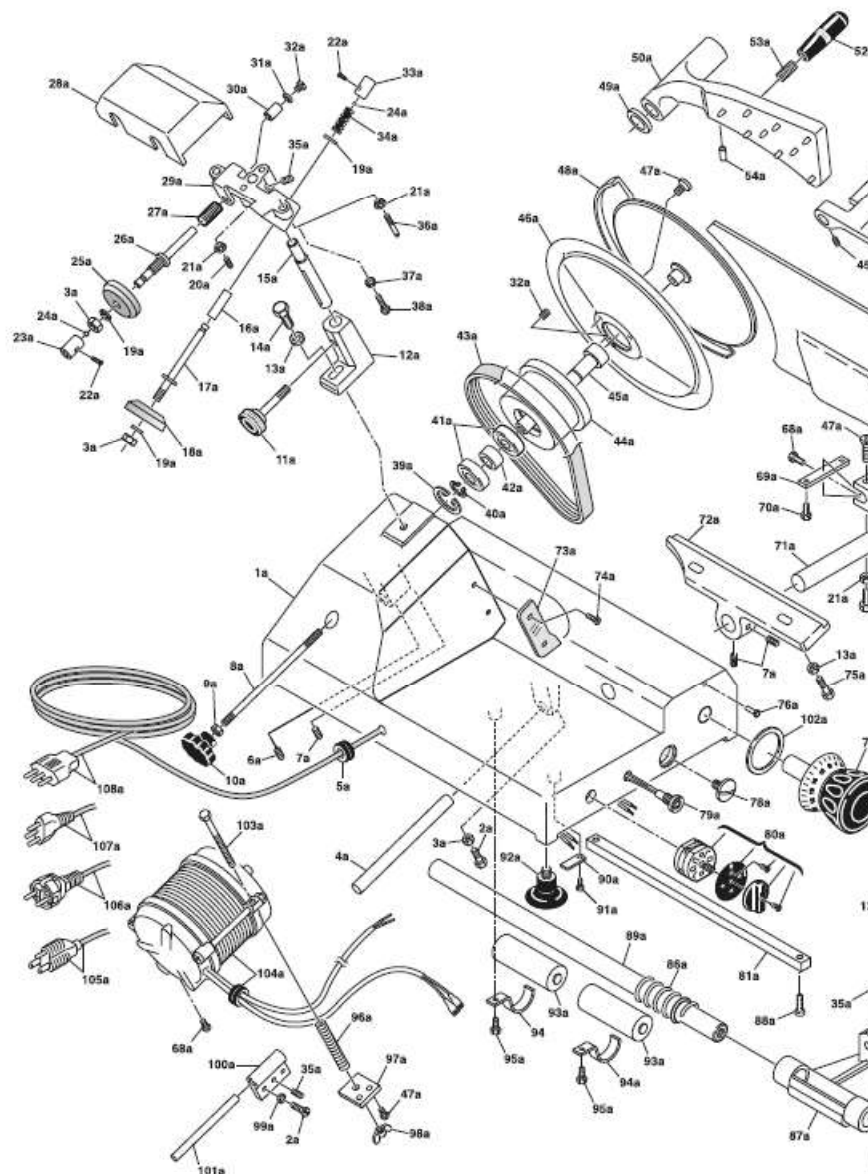

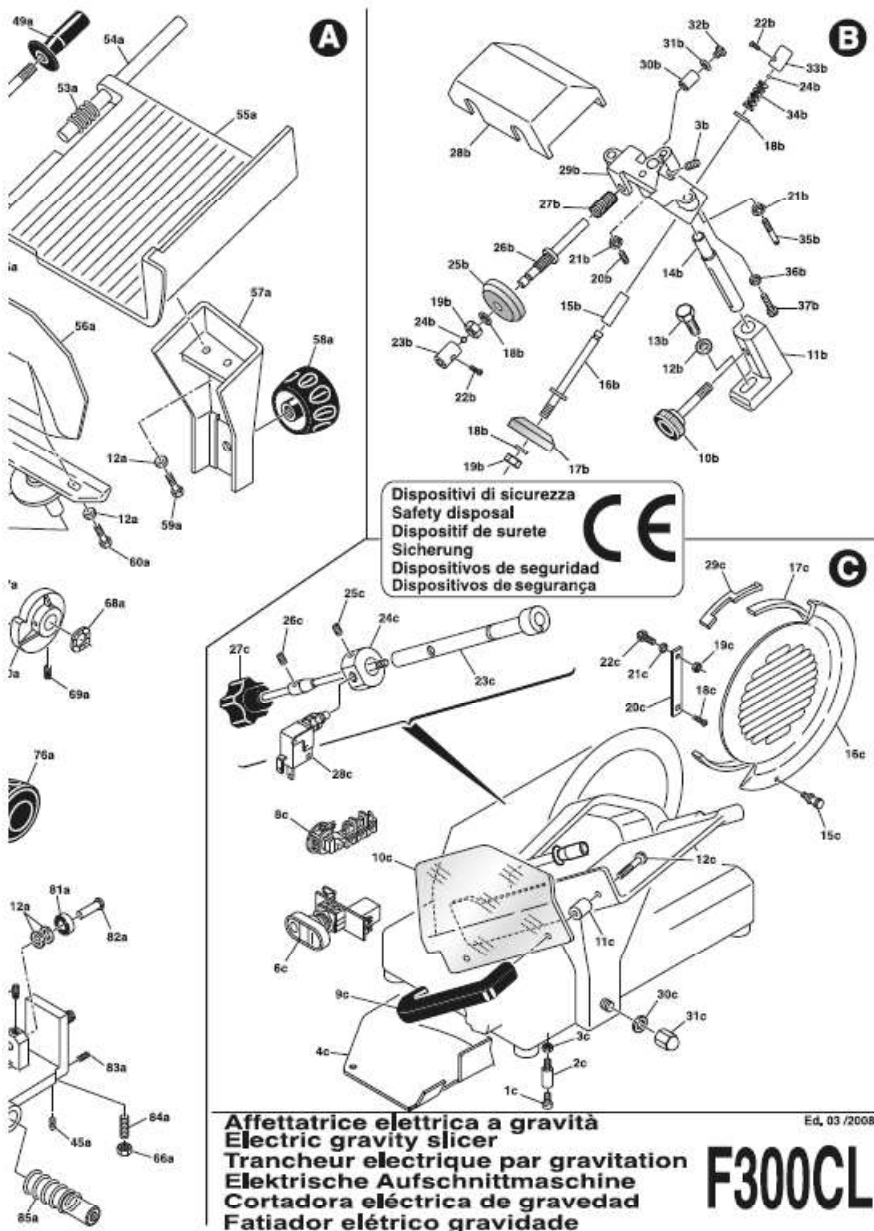

## 7. MAINTENANCE

### 7.1 - Generalities

In addition to the cleaning operations described in the previous paragraphs, it is necessary to perform some periodic maintenance operations to guarantee the slicer efficiency over time. The maintenance interventions allowed to the user are the following:

- Blade sharpening: periodically (periodicity and duration obviously depend on the equipment use; working times and type of the processed product).
- Lubrication of the tray sliding guides: weekly.
- Lubrication of the product grip sliding rod: weekly.
- Visual check of the power cord and of the cable gland on the machine base conditions: periodically.

#### WARNING

Maintenance interventions must always be performed when the machine is disconnected from the mains supply network and, if another position is not specifically requested, with the slices thickness control knob placed on '0'.

The maintenance interventions to entrust exclusively to personnel authorized by the manufacturer are the following:

- Blade replacement;
- Sharpener grinding wheels replacement;
- Motor belt tension adjustment;
- Motor driving belt replacement;
- Crankcase electrical system components replacement;
- Structural parts repair, crankcase components repair.

### 7.2 - Blade sharpening

Accurately clean the machine as indicated in the previous paragraphs before proceeding with the operations.

**WARNING**

The sharpening can be performed until a decrease of 12 mm of the blade diameter nominal value. Beyond this value IT IS MANDATORY TO REPLACE THE BLADE, entrusting the operation EXCLUSIVELY to personnel authorized by the manufacturer.

**8. PERFORMING THE SHARPENING**

**8.1 - Versions with sharpener to be applied**

**WARNING**

Cutting hazard! Use protective cut- and tearresistant gloves and perform all operations with extreme care. PAY ATTENTION AT ALL TIMES !

1. Accurately clean the blade with denatured alcohol in order to degrease it;
2. Operate the control knob (6) by turning it leftward to take it to the maximum of openness;

**Figure 09**

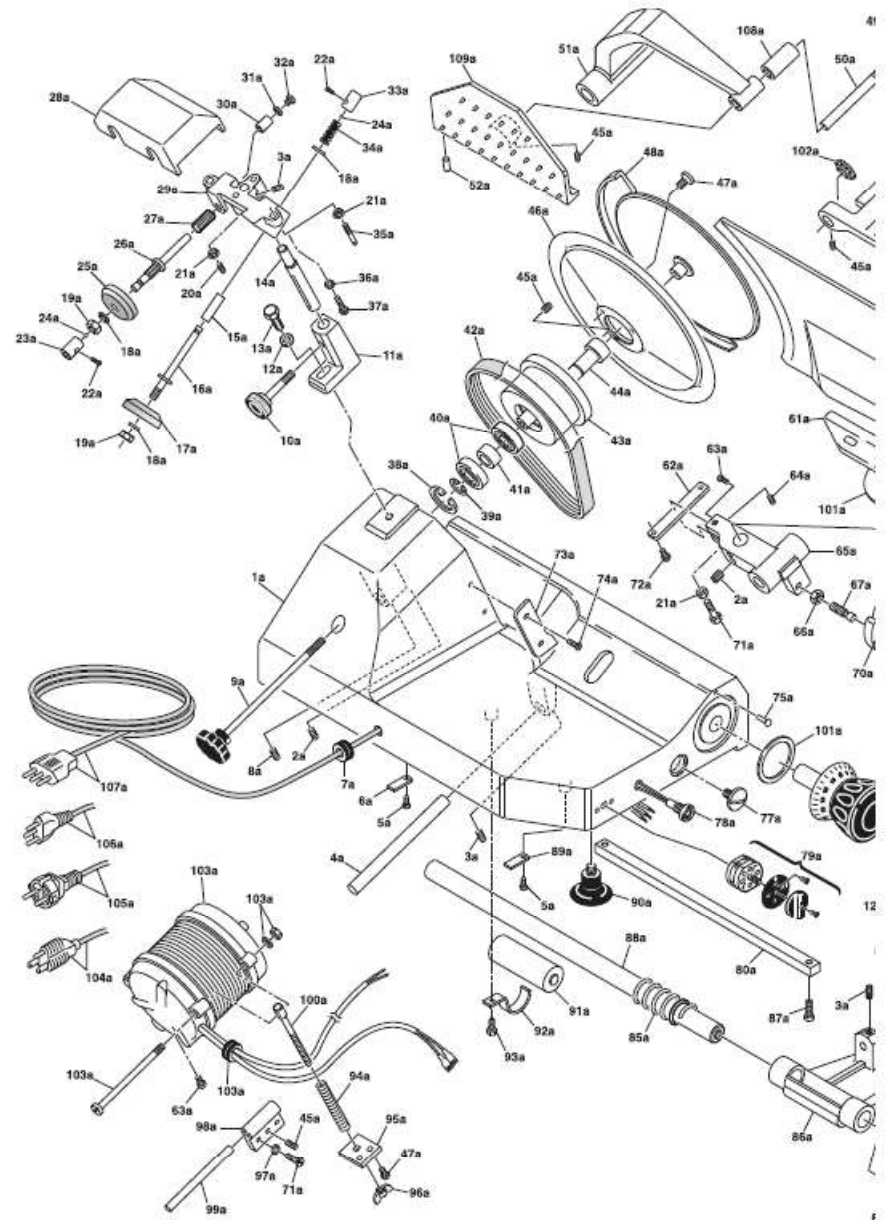
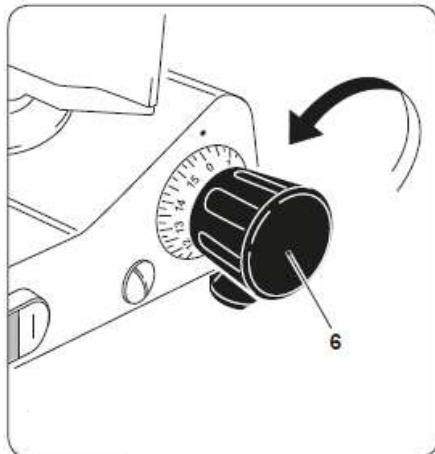

- Remove the sharpener from the supplied bag.
- Unscrew the knurled knob (23) and insert the threaded metallic pin in the hole (y) (specifically prepared on the product tray "8").
- Make sure that the two emery-wheels (x - x1) are pointed towards the blade to be sharpened, easing the operation by pressing on the lower wheel "x1" button with your finger.

Figure 10

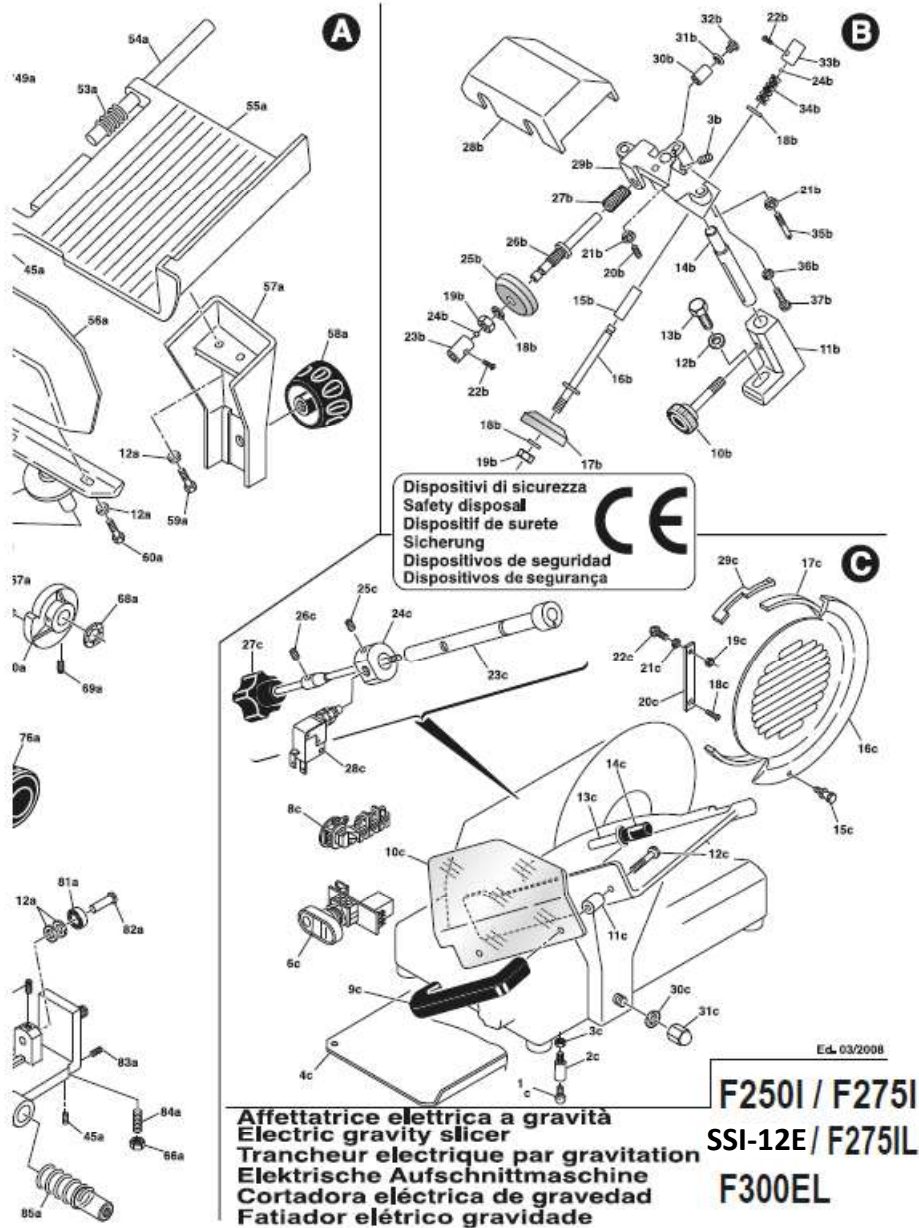
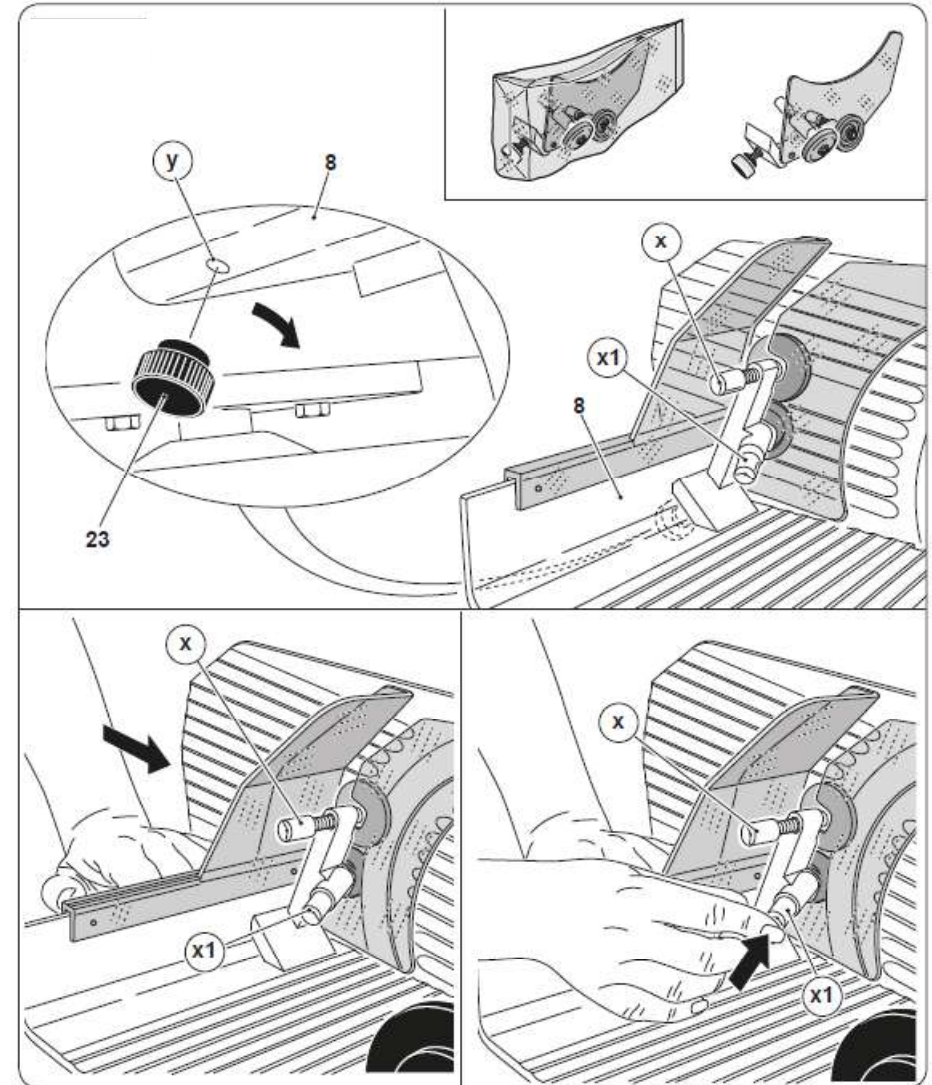

- The lower wheel (x1) will have to remain inserted for almost half of its diameter between the blade, on which it will lean, and the regulator plane.
- Insert the plug in the power socket and start the blade (with the appropriate command) while keeping the product tray (8) (and the sharpener) still through the handle (15).
- Let the blade rotate for about 30÷40 seconds.
- Stop the blade movement by pressing the red button "0" (4).
- Check, with a slight shift (using a pencil) to the outside of the blade, if some burr has formed.

**WARNING**

**We recommend to perform this checking very carefully as it is a very sharp body.**

- Ascertained the formation of burr, restart the blade and keep the wheel (x) button pressed for 3/4 seconds.

**Figure 11**

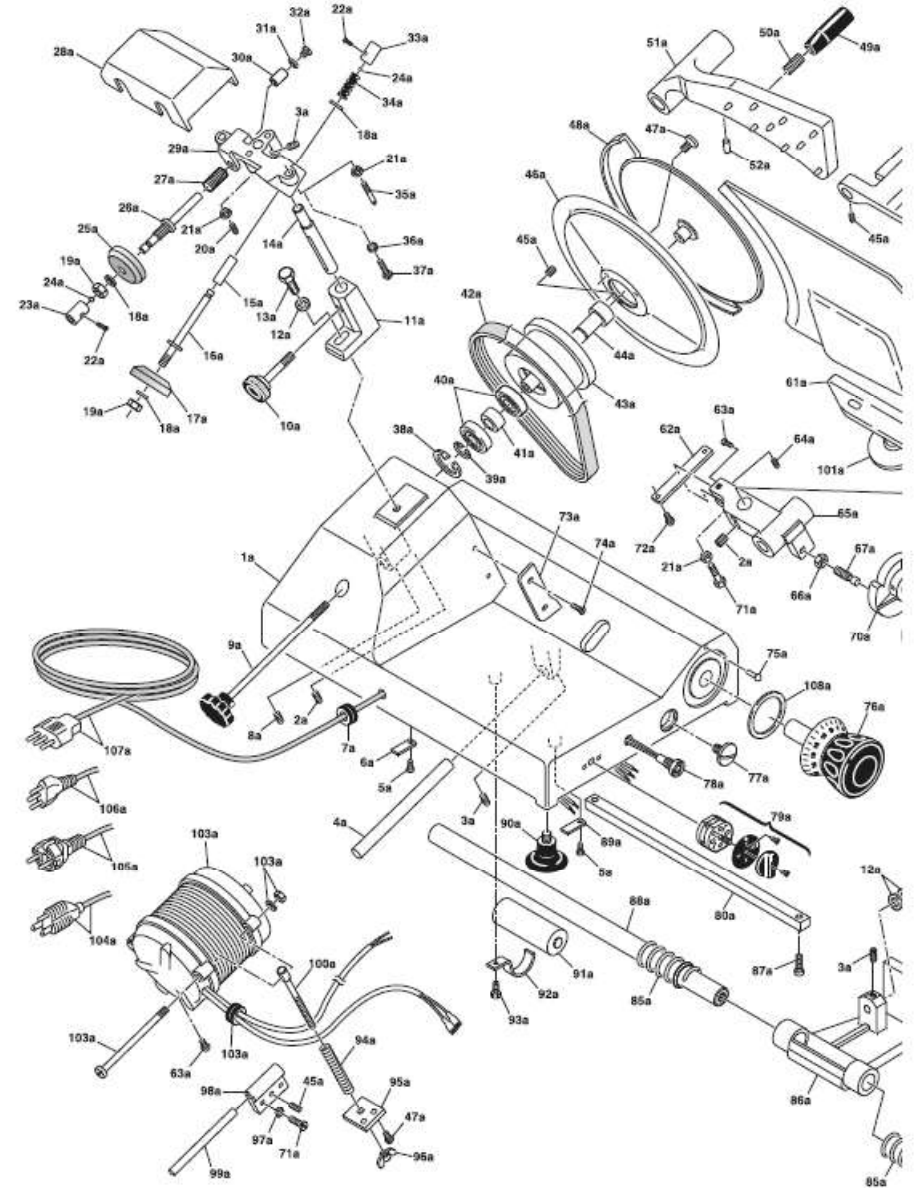
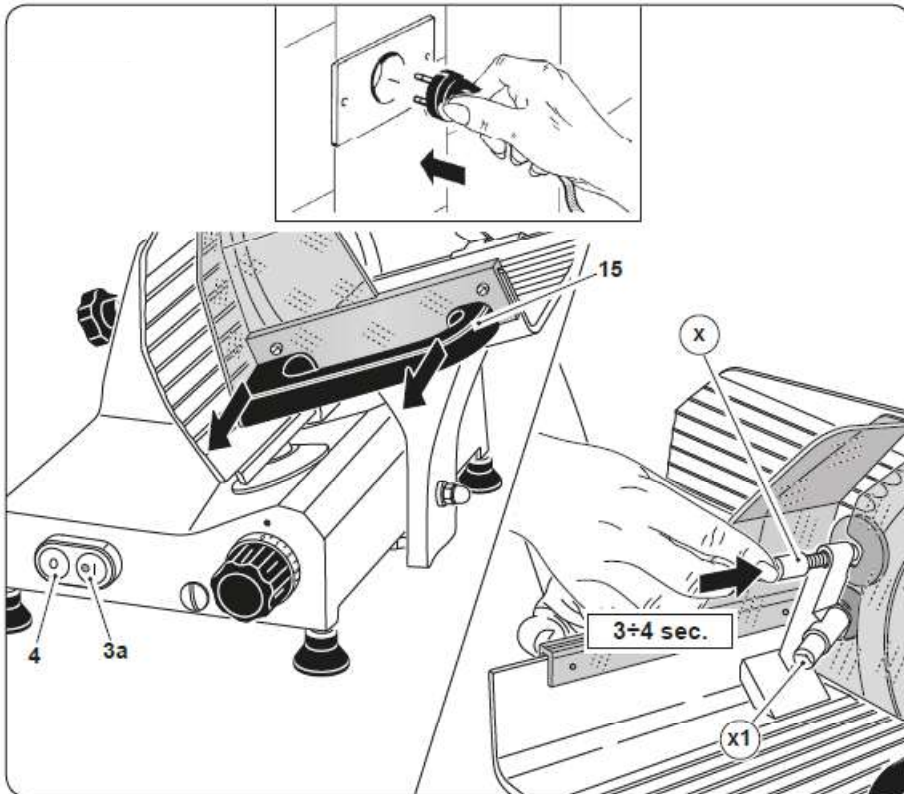

## 8.2 - Versions with built-in sharpener

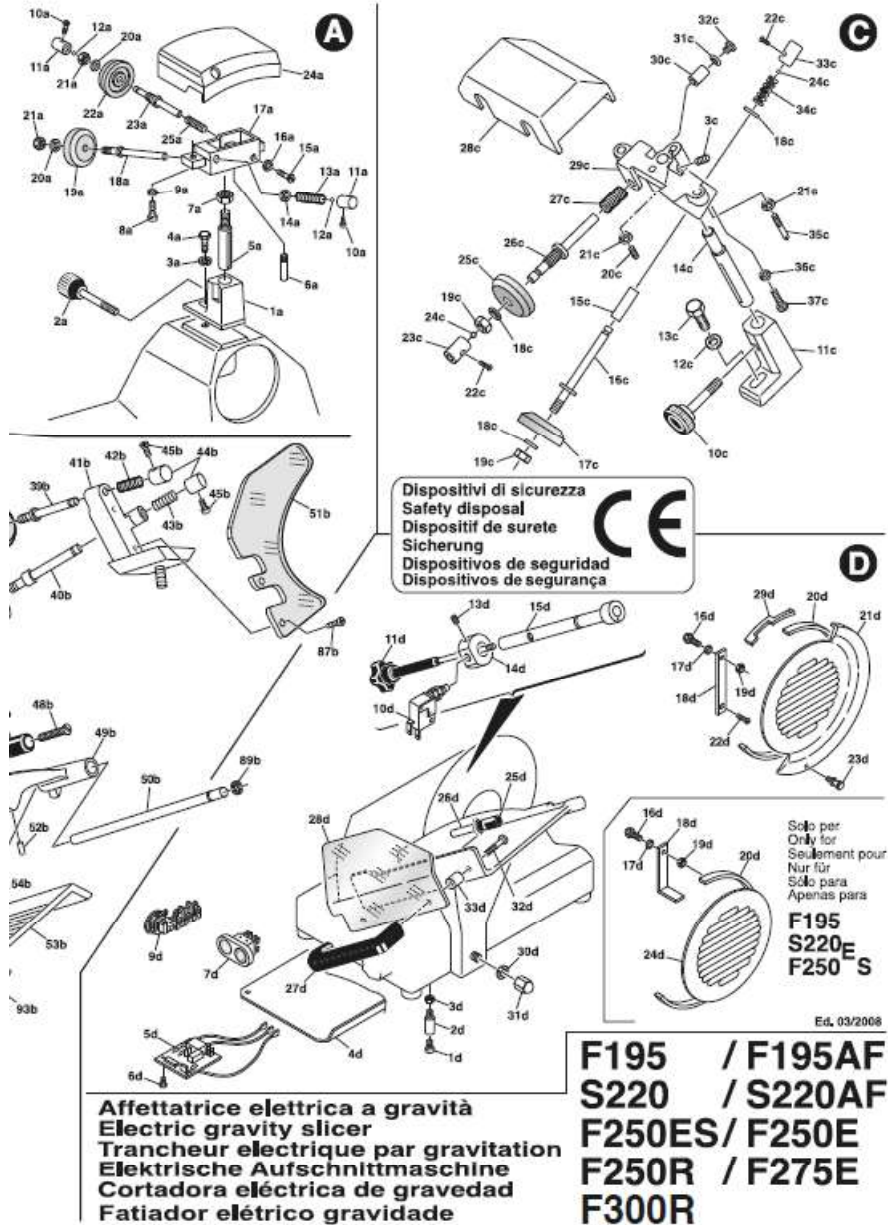

### WARNING

**Cutting hazard! Use protective cut- and tearresistant gloves and perform all operations with extreme care. PAY ATTENTION AT ALL TIMES !**

For the blade sharpening to be performed periodically as soon as a decrease in the cutting capacity is felt, it necessary to observe the following instructions:

1. Accurately clean the blade (11) with denatured alcohol in order to degrease it after disconnecting the plug from the power socket;
2. Loosen the knob (20a), lift and rotate the sharpening appliance (20) by 180° and insert the wheels on the slicer blade. Relock the knob (20a);

Figure 12

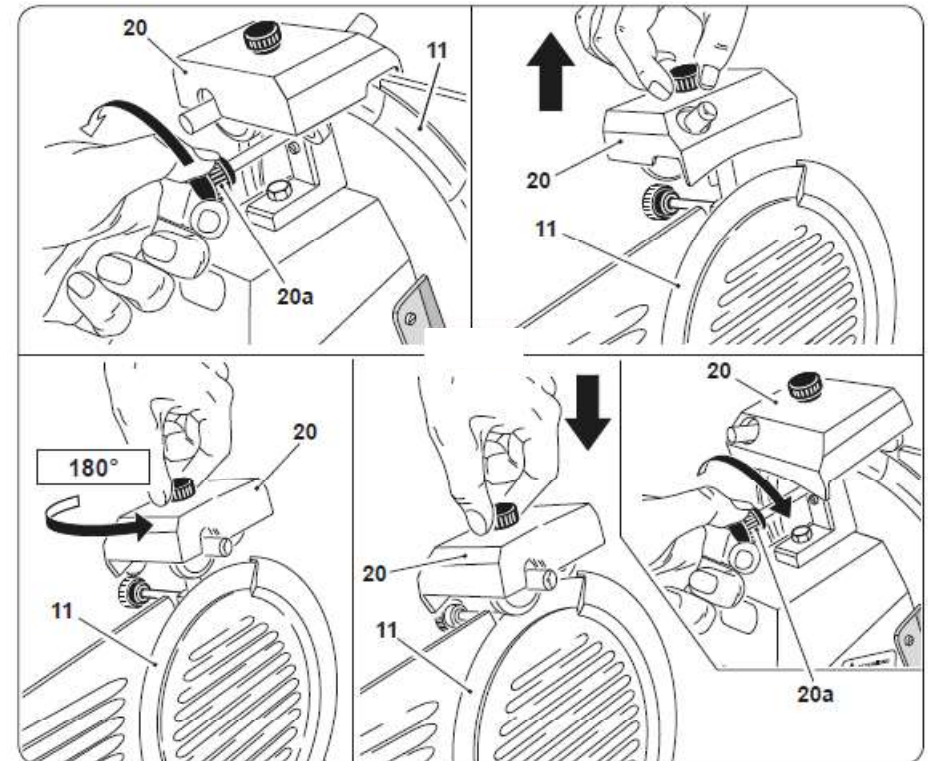

3. Start the switch (1) and press the button (x2);

4. Let the blade rotate for about 30/40 seconds, then stop the blade by operating the switch (1) and, with a slight shift (using a pencil) to the outside of the blade, check if some burr has formed;

**WARNING**

We recommend to perform this checking very carefully as it is a very sharp body.

Figure 13

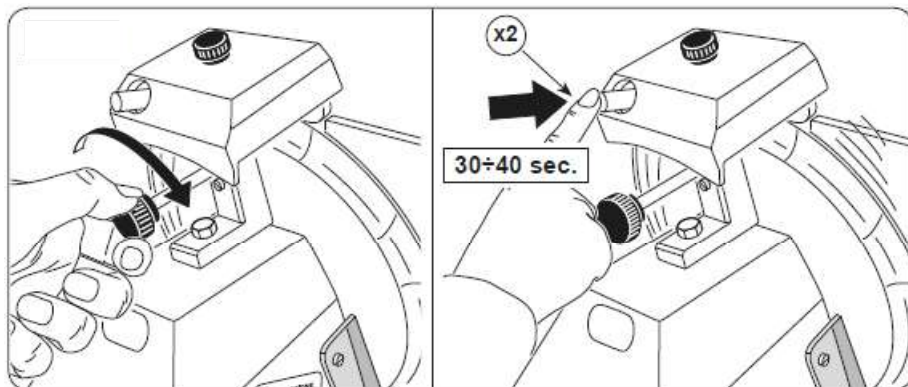

5. Ascertained the formation of burr, operate the switch (1) for 3/4 seconds again by pressing the buttons (x2 and x3) at the same time;

**DO NOT EXTEND THIS OPERATION BEYOND THE ABOVE MENTIONED FEW SECONDS TO AVOID THE HARMFUL TORSION OF THE BLADE WIRE.**

Figure 14

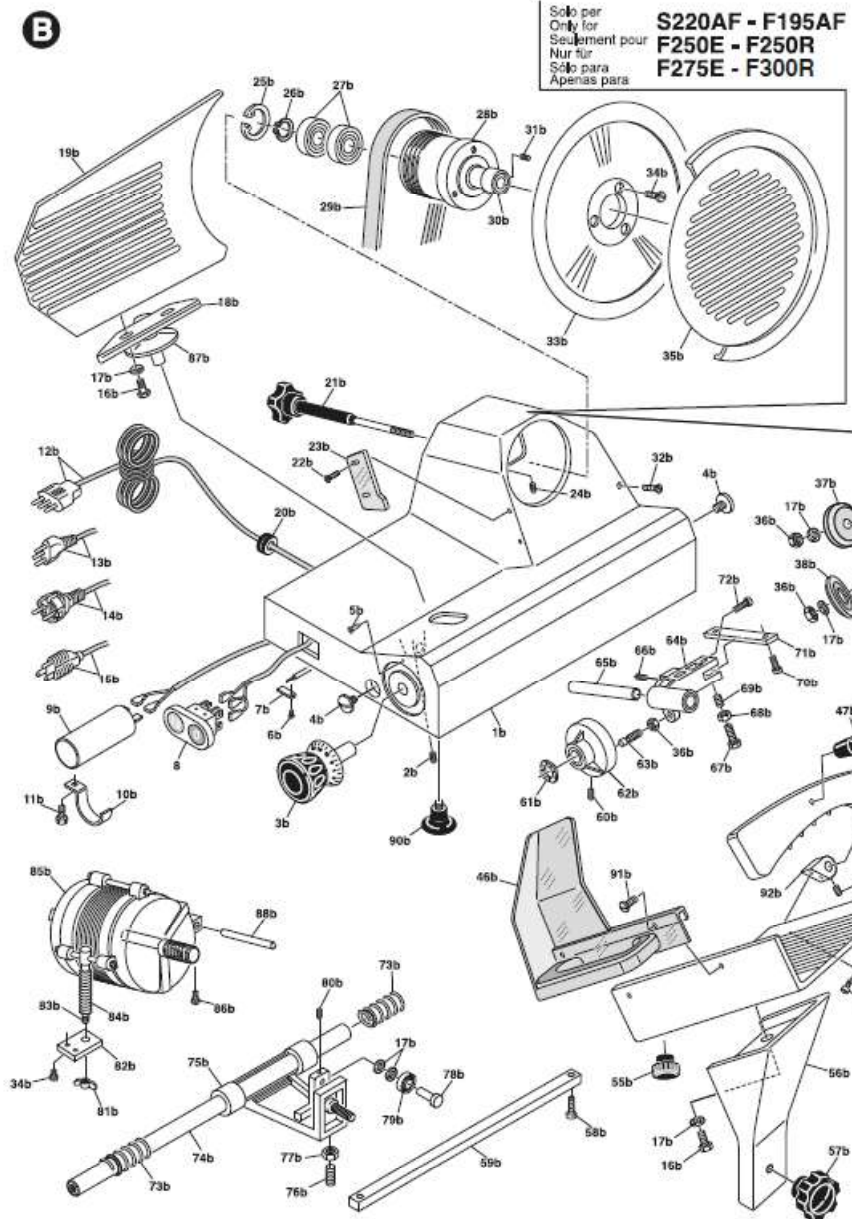
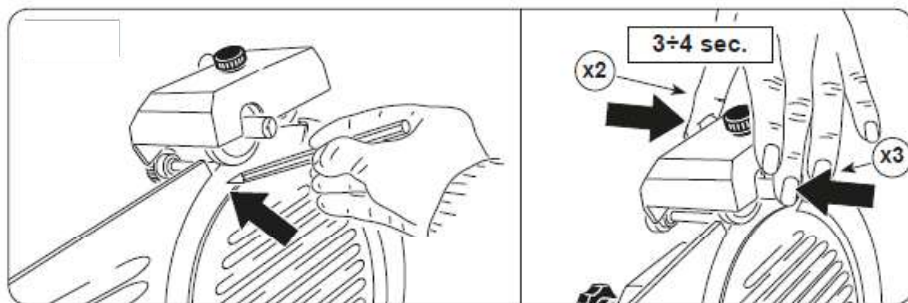

6. After completing sharpening, we advise cleaning the wheels using a small brush soaked in alcohol;

7. Return the sharpener to its original position after the sharpening operation.

## 9. LUBRICATION

### 9.1 - Tray sliding guides and product grip sliding rod (weekly)

Only use oil (Fig. 14a).

Only use white Vaseline oil (Fig. 14b).

- Apply a small quantity of oil on the rod and let the corresponding group slide 3-4 times;
- Clean where necessary removing wiping excessive lubricant.

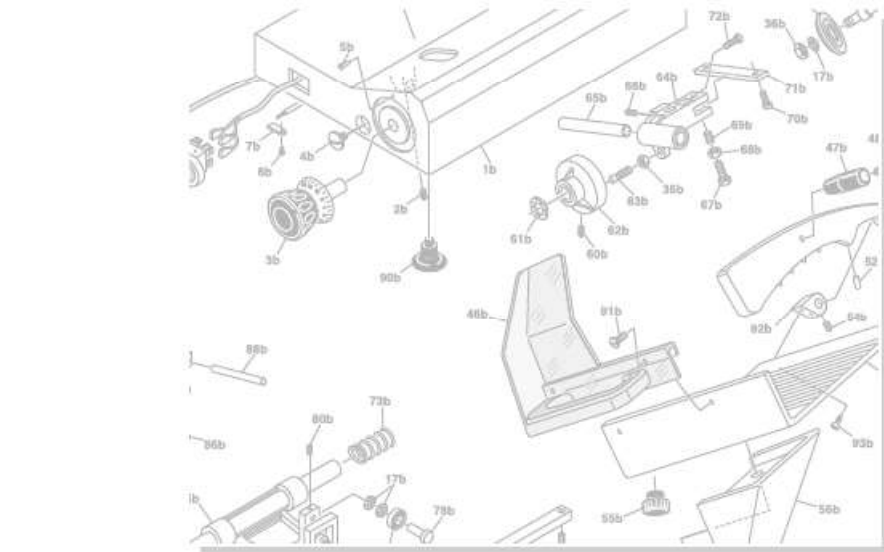
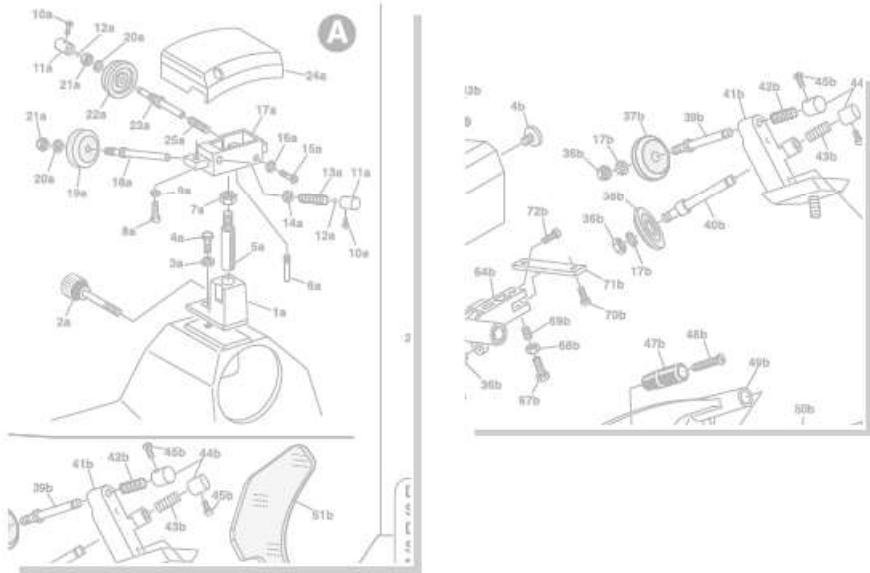

**Spare parts**

Figure 15

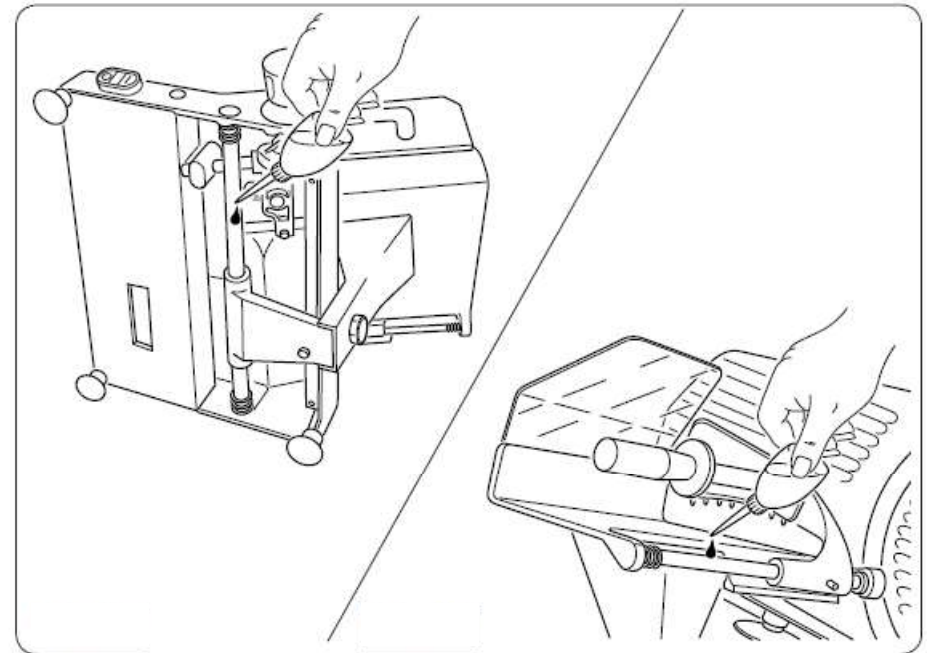

When, after a given time, the slicer emits an unusual noise because of the belt adjustment (30), proceed as follows:

- Disconnect the plug from the power socket.
- Lift the slicer and place it on its side (figure “24”).

**Make sure that the slicer is stable and can not inadvertently fall.**

- Unscrew the feet (5).
- Unscrew the screw (31) and remove the casing (32).
- Loosen the lock nut (33). Turn the nut (34) until you obtain an optimal belt (30) tensioning.
- Tighten the lock nut (33).
- Reposition the casing (32) with the screws (31), then reposition the feet (5).

**Do not over-tighten the belt. In the rotation, the motor could force and the belt may be damaged.**

Figure 16

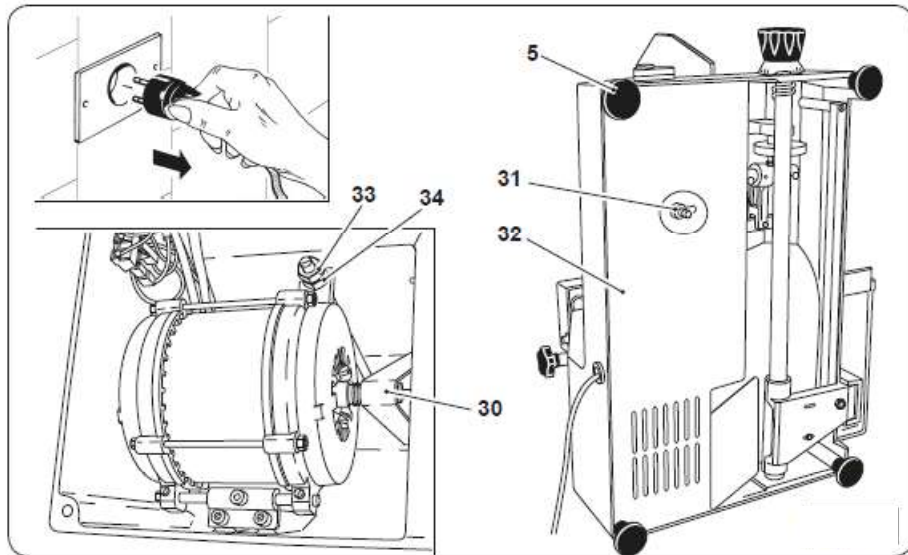

**Only for personnel authorized by the manufacturer**

G/V = Yellow/Green  
M = Brown  
B = Blue

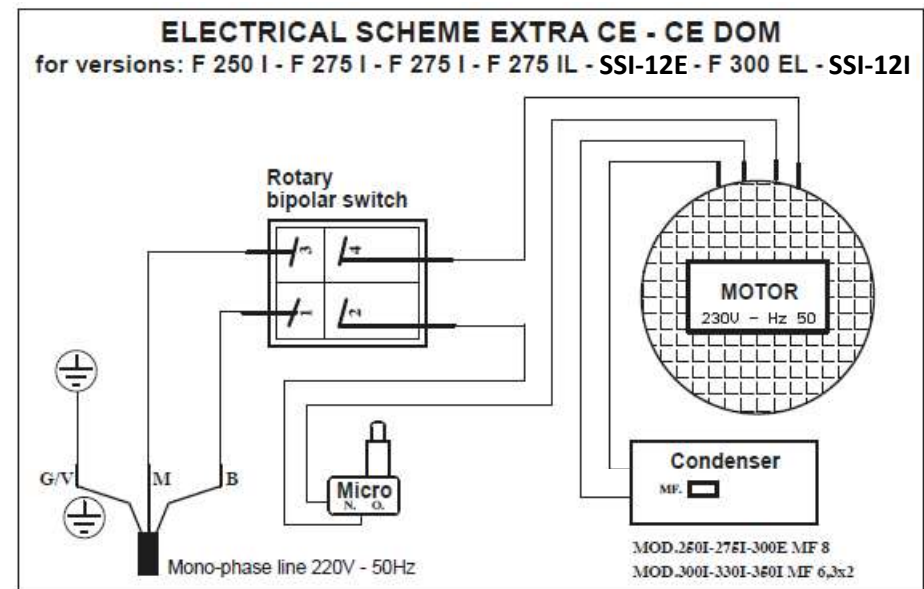
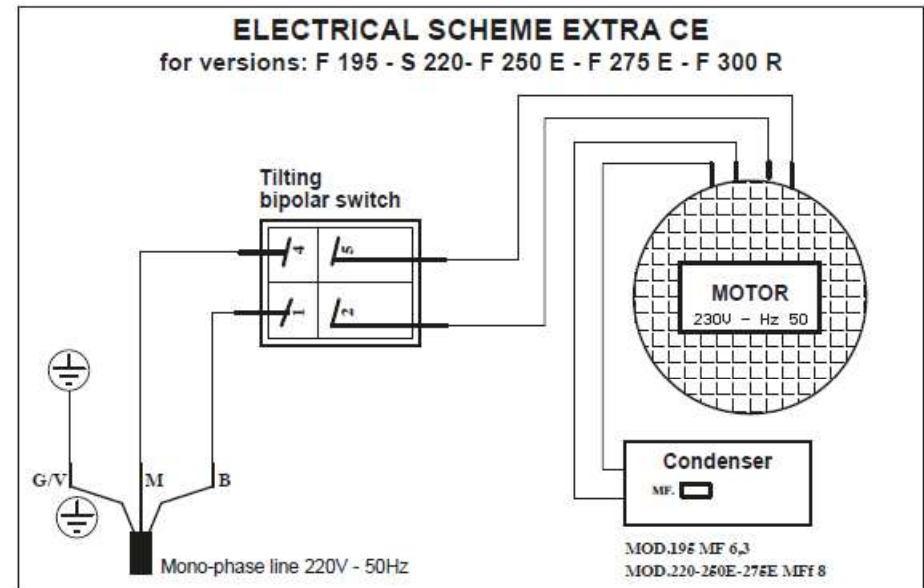

G/V = Yellow/Green  
M = Brown  
B = Blue

**Only for personnel authorized by the manufacturer**

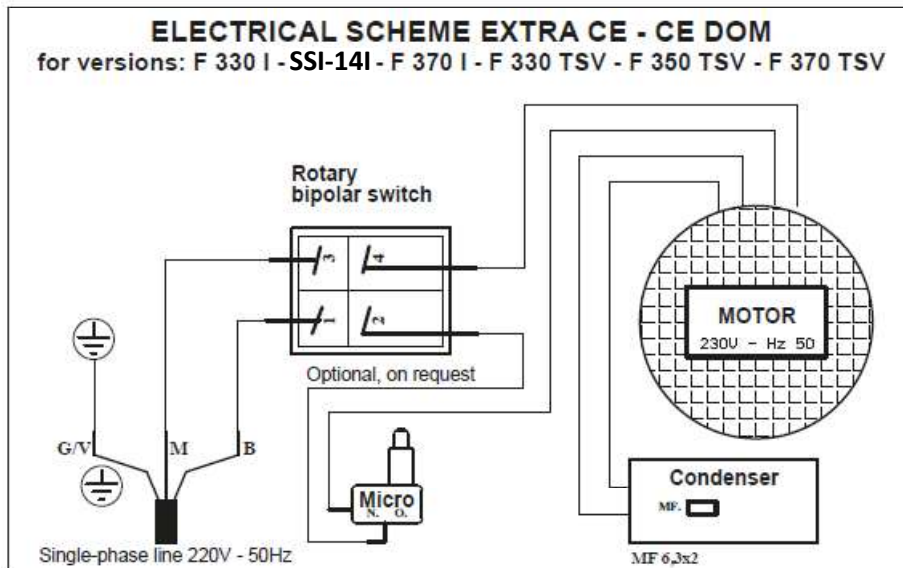
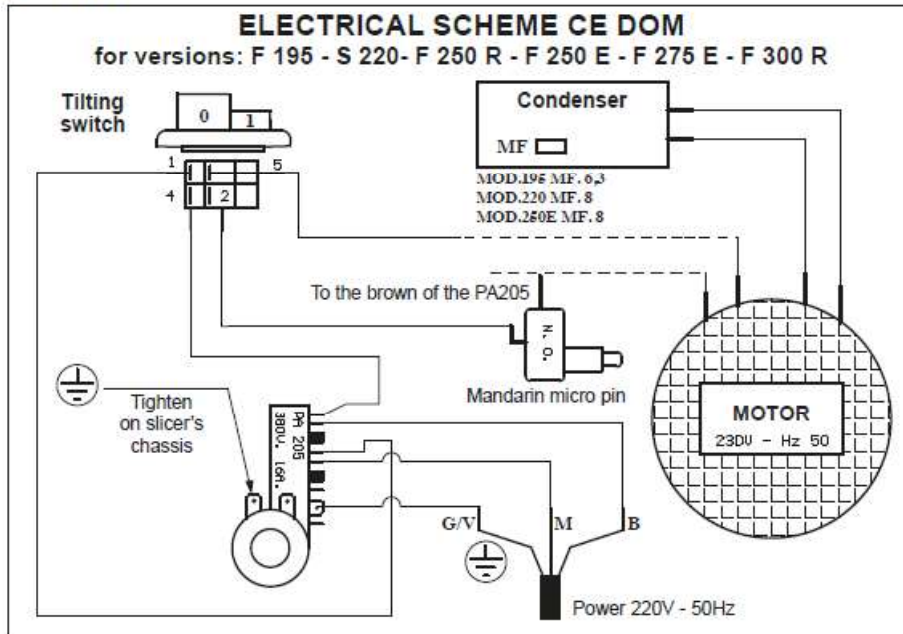

## 10. TAKING THE SLICER OUT OF SERVICE

### 10.1 - Correct procedure

A machine comprises:

- Aluminium-alloy frame.
- Stainless-steel inserts and components.
- Electrical parts and electrical cables.
- Electrical motor
- Plastics, etc.

- When commissioning third parties to perform dismantling and demolition, only businesses authorised to dispose these materials should be employed.

- When demolishing without outside assistance, sort the various types of material and hand over to authorised businesses for disposal.

**ALWAYS comply with the current legislations of the country in which the slicer is utilised.**

#### WARNING

**ALWAYS consult the manufacturer or authorised service staff as regards removal and disposal of the blade (11) so that this can take place in complete safety.**

#### WARNING

**DO NOT ABANDON SCRAPS AS THEY ARE A SERIOUS DANGER FOR PEOPLE, ESPECIALLY CHILDREN, AND ANIMALS.**

Refer to the "Guide to the treatment of waste equipment" paragraph at page 12.

## 11. TROUBLESHOOTING

- The following information are intended to aid in identifying and correcting defects and faults that may occur during use of the machine.

**Some failures can be resolved by the user; others require precise technical skills or special skills, and must be carried out by qualified personnel with recognized expertise and experience in the specific area of intervention.**

### WARNING

**Do not disassemble the internal parts of the slicer. The manufacturer declines all responsibility for any damage caused by tampering.**

- The table below shows the most common problems that occur during the use of the slicer and the operations required to eliminate the possible causes.

PROBLEM	CAUSES	SOLUTIONS
Pressing the green or white button won't start the machine.	No power supply.	Check that the plug is properly inserted.
	Defective electrical control circuit.	Call technical assistance.
The machine will not start, and you hear a continuous noise like a buzz (only machines with three-phase motor).	The motor is functioning single-phase.	Immediately press the black or red button and have the power supply cable and the upstream circuits by qualified personnel.

PROBLEM	CAUSES	SOLUTIONS
Pressing the green or white button will start the machine, but the operation light will not turn on.	Defective indicator.	Do not use the machine with light indicator off; promptly consult the customer service.
The machine starts but vibrates, the motor is very hot and there is bad smell.	Defective motor or transmission.	Do not use the machine, promptly consult the customer service.
The machine under load slows or stops.	Defective transmission.	Consult the customer service.
Excessive resistance at cutting of the product.	The blade is blunt.	Sharpen the blade.
The slices are ragged and/or irregularly shaped.	The blade is blunt.	Sharpen the blade.
	Blade excessively worn.	Consult the customer service.
The blade sharpening is unsatisfactory.	Worn wheels.	Replace the wheels; Call the customer service.
The product tray does not slide.	Insufficient guides lubrication.	Lubricate.
Pressing the black or red button won't stop the machine.	Defective electrical control circuit.	Stop the machine pulling the plug from the network and call customer service.

### NOTE TO USER

This publication shall consist of n°80 pages as specified below:

- Title page with Notes for the User (no print back);
- Index of contents, pag. 3;
- From pag. 3 to pag. 75: progressive numeration.

*The manufacturer reserves its right to bring changes to the information indicated in the manual without the obligation to communicate it in advance, as long as they don't alter safety.*