

## INSTRUCTIONS MANUAL



Skyfood Equipament LLC

**OFFICE**

175 SW 7th Street - Suite # 2416

Miami, FL 33130

**1-800-503-7534 | 305-868-1603**

UG0177 - INGLÊS

Data de Correção: 03/07/2023



12" HEAVY DUTY SLICER

**312EC1**

- BESIDES THIS EQUIPMENT, A COMPLETE RANGE OF OTHER PRODUCTS ARE MANUFACTURED, CONSULT OUR DEALERS  
- DUE TO THE CONSTANT IMPROVEMENTS INTRODUCED TO OUR EQUIPMENTS, THE INFORMATION CONTAINED IN THE PRESENT  
INSTRUCTION MANUAL MAY BE MODIFIED WITHOUT PREVIOUS NOTICE.



**Warranty Registration**



**Questions about how to complete this form?**

Call 1-800-503-7534 / 305-868-1603

**Return completed form to:**

175 SW 7th Street - Suite # 2416

Miami, FL 33130

North Miami, FL 33181 - USA

**Or fax form to:**

786 522 6765

**User Details**

\* Contact Person: \_\_\_\_\_

\* Business type:

- |  |   |
|--|---|
| <input type="checkbox"/> Bakery and Bagel Operations                   | <input type="checkbox"/> Mass Merchandiser with Grocery                   |
| <input type="checkbox"/> Bakery (Associated with Restaurant)           | <input type="checkbox"/> Mass Merchandiser with NO Grocery                |
| <input type="checkbox"/> Bowling Center                                | <input type="checkbox"/> Meat Packer and Purveyor                         |
| <input type="checkbox"/> Business and Industry In-House Feeding        | <input type="checkbox"/> Other Business that prepares or serves food      |
| <input type="checkbox"/> Butcher                                       | <input type="checkbox"/> Other Business that sells but doesn't serve food |
| <input type="checkbox"/> Catering                                      | <input type="checkbox"/> Pizza (Dine In / Carry Out)                      |
| <input type="checkbox"/> Club Stores                                   | <input type="checkbox"/> Restaurants (Independent / Chain)                |
| <input type="checkbox"/> Convenience Store                             | <input type="checkbox"/> School   |
| <input type="checkbox"/> Country Club                                  | <input type="checkbox"/> Stadiums / Coliseum                              |
| <input type="checkbox"/> Delicatessen (Chain / Restaurant)             | <input type="checkbox"/> Supermarket / Grocery                            |
| <input type="checkbox"/> Delicatessen (Independent and Non-Restaurant) | <input type="checkbox"/> Theme Park                                       |
| <input type="checkbox"/> Food Store                                    | <input type="checkbox"/> University / College                             |
| <input type="checkbox"/> Government                                    | <input type="checkbox"/> Vineyard / Winery                                |
| <input type="checkbox"/> Hospital                                      | <input type="checkbox"/> Warehouse Clubs                                  |
| <input type="checkbox"/> Lodging                                       | <input type="checkbox"/> Wholesale Baking Operation (Non-Institutional)   |

\* Company Name: \_\_\_\_\_

\* Address: \_\_\_\_\_

\* City: \_\_\_\_\_

\* State: \_\_\_\_\_ \* Zip Code: \_\_\_\_\_

\* Phone: \_\_\_\_\_ Fax: \_\_\_\_\_

\*\* E-mail: \_\_\_\_\_

Web page: \_\_\_\_\_

- I would like to join the Mail List.       I would like to join the E-mail List.

**Product Details**

\* Product Commercial Item: \_\_\_\_\_

The Product Commercial Item can be found on the machine Product Identification Label.

\* Serial Number: \_\_\_\_\_ \* Confirm Serial Number: \_\_\_\_\_

This information, the Product Serial Number, can also be found on the machine Product Identification Label.

\* Proof of Purchase:  Yes  
 No

\* Purchased On: \_\_\_\_/\_\_\_\_/\_\_\_\_ (mm / dd / yyyy)

\* Purchased From: \_\_\_\_\_  
Company Name

\* Indicates required field.      \*\* Indicates required field, not mandatory by Fax.

**IMPORTANT:**  
The operator must be familiar with the content and understand the instructions before operating this equipment.

**1. BRIEF INTRODUCTION FOR THE PRODUCT**

Model 312EC1 Slicer is a new and improved food Slicer. Angle feed easy to operate. New design with curved lines, no crevices or gaps. Removable carriage system and for easy cleaning and sanitation.

**1.1 Technical Characteristics**

**TABLE 01**

CHARACTERISTICS	UNIT	312EC1
Dimension	in	24" x 19 1/4" x 23 5/8" (LxWxH)
Weight	in	74.8
Slicing dimension	lb	13 3/4" x 7 7/8" (LxW)
Slicing thickness	lb	0-5/8"
The diameter of the blade	lb	12"
Power of the motor	W	420
Voltage	V	110
Frequency	Hz	60

## 2. OPERATION

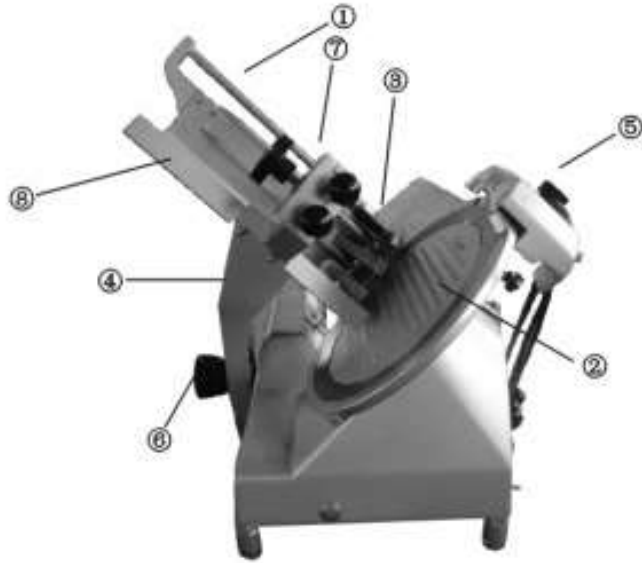

- 01 – Meat depressor axle
- 02 - Blade cover
- 03 – Gauge plate
- 04 – Carriage bracket

- 05 – Meat clip device
- 06 – Sharpener assembly
- 07 – Meat clip device
- 08 – Food tray

1. Put the machine on a work table firmly. Then connect the ground wire.
2. Raise up the Gauge Plate and put frozen meat onto the Food tray, and then press the green ON button.
3. Adjust the slicing thickness according to your needs, and then push and pull the food tray to slice the product.

c) Redirecting a customer searching for a SKYFOOD product to a product other than a SKYFOOD product.  
 d) Indicating or implying that a price that is below the IMAP price can be obtained at the online cart or checkout stage (e.g. “See price in cart”, “Email for better price”, “Click here for lower price”, “Log in for price”, “Add to cart for lower price”, “Chat for price”).  
 IMAP does not establish maximum advertised prices. All internet dealers and reseller websites may offer SKYFOOD products at any price in excess of the IMAP.

**At the sole discretion of Skyfood, failure to comply with IMAP, intentional and/or repeated failure to abide, it reserves the right to put internet dealers and reseller websites account on hold, until prices are adjusted.**

SKYFOOD can terminate or amend any part or all of this policy at any time without prior notice.

### Return Policy

All returns are subject to the prior authorization of SKYFOOD, in its discretion. Buyer must contact Buyer Support at **305-868-1603**, or by fax at **305-866-2704**, or via e-mail at **support@skyfood.us** in order to request a Return Authorization number (“RA”) providing, along with the identification of the goods, a specific reason for return. Buyer Support will either authorize or deny the request for return. Only NEW and UNUSED items are acceptable for return. Unauthorized returns will be destroyed and no credit issued. All authorized returned goods must be shipped freight prepaid to SKYFOOD.

All returned goods are subject to a 20% handling/restocking fee. All returns must be returned in their original packaging and within thirty (30) days from the shipping date.

**SKYFOOD reserves the right to change the terms and conditions of this Commercial Policy at any time without any prior notice. It also reserves the right to change the design and specifications of its equipment or any related documentation at any time. The end user is not entitled to upgrades or refunds resulting from these changes.**

These Terms and Conditions were last updated on May 26th, 2022.

### SKYFOOD EQUIPMENT LLC - SERVICE

Unless otherwise specified, new SKYFOOD products, excluding accessories, sold by SKYFOOD EQUIPMENT, LLC. (“SKYFOOD”), for use only in the continental United States (collectively, “Products” or singularly, “Product”), are warranted to be free from defects in materials and workmanship for a period of one (1) year from the date of purchase by the original purchaser/user (“End User”), or eighteen (18) months from the date of shipment from SKYFOOD’s warehouse, whichever expires first. Several new products and accessories may be warranted for a period other than one (1) year while others may be subject to travel limitations, as specified on the products Instruction Manual. **Proof of purchase must be presented; if not this warranty will be VOID.** No warranty is given or implied to a subsequent transferee or any other third party. This warranty is expressly conditional upon SKYFOOD being notified of any defects in materials or workmanship within five (5) days of its occurrence, within the warranted time period. If a notice of a claim under this warranty is timely made by the End User, SKYFOOD or a SKYFOOD’s designated service company (“Service Company”), will repair or replace the Product, at SKYFOOD’s discretion, subject to the additional conditions hereinafter described.

This warranty shall not apply if damage occurs from improper installation or maintenance performed by an unauthorized service company (“Service Company”), wrong voltage, nor to the extent that Products or parts have been used other than in conformance with operating and maintenance instructions, subjected to misuse or abuse or damaged by accident, acts of God, abnormal use, stress or any other matter unrelated to SKYFOOD, and beyond its reasonable control. **This warranty does NOT cover service labor and travel to perform adjustments on products and/or accessories.** In addition to wear and tear of certain items, such as, but not limited to; glass parts, blades, stones, chopper cutting knives, plates, slicing knives, cutting disc, gaskets, oil changes, sealing tape, heat seal wires, worm gears, self-lubricating bushings, carbon brushes for electric motors, and other parts expendable by nature and that need to be replaced frequently. **Electrical components are subject to natural wear and tear, and are NOT covered by this warranty. THIS WARRANTY EXCLUDES ALL ORAL, STATUTORY, EXPRESS OR IMPLIED WARRANTIES WHICH MAY BE APPLICABLE TO SKYFOOD, INCLUDING, BUT NOT LIMITED TO, ANY IMPLIED WARRANTY OF MERCHANTABILITY AND FITNESS FOR PARTICULAR PURPOSE.** Under no circumstances shall SKYFOOD be liable for loss of use, revenue or profit or for incidental or consequential damages. SKYFOOD shall under no circumstances be liable for any loss, damage, concealed damage, expense or delay of goods for any reason when said goods are in the custody, possession or control of third parties selected by SKYFOOD to forward, enter, clear, transport, or render other services with respect to such goods. The sole and exclusive remedy for breach of any warranty is limited to the remedies provided in the paragraph above.

All products held at non-commercial facilities or domiciles, must be taken or shipped, shipping charges prepaid, either to SKYFOOD’s facility or a SKYFOOD’s designated service company (“Service Company”). Products held at commercial facilities and weighing less than seventy (70) lbs. must be taken or shipped, shipping charges are prepaid, either to SKYFOOD’s facility or to a Service Company. Mileage or travel time will NOT be paid. SKYFOOD offers a limited on-site warranty for products ONLY held at commercial facilities, whose net weight exceeds seventy (70) lbs., provided they are installed in a location that is within a thirty (30) mile radius of a Service Company. **End Users are responsible for all extra travel and mileage rates.** In this case, warranty services will be provided during regular business hours.

Accessories will be replaced or repaired under warranty, for a period of (30) days, beginning from the date of purchase by the original purchaser/user (“End User”), or eighteen (18) months from the date of shipment from SKYFOOD’s warehouse, whichever expires first.

This warranty shall not take effect until a properly completed and executed **WARRANTY REGISTRATION** form has been received by SKYFOOD EQUIPMENT, LLC, within thirty (30) days from the date of purchase. The **WARRANTY REGISTRATION** is available either in the Instruction Manual of every Product or at SKYFOOD’s website [www.skyfood.us](http://www.skyfood.us). The End User must fill out the **WARRANTY REGISTRATION** form and send it to SKYFOOD according to the instructions posted on the referred website. **Failure to do so will VOID the warranty.**

**No extended warranties for third party products. There are no other express warranties or conditions other than the one offered by each manufacturer for products sold by SKYFOOD, not under the SKYFOOD brand.**

For questions or assistance, do not return the product or accessories to the store, please call Toll Free 1-800-503-7534, or visit the Customer Service section at [www.skyfood.us](http://www.skyfood.us). For faster service please have the items name, serial number, and proof of purchase for the operator to assist you.

**SKYFOOD reserves the right to change the terms of its limited warranty at any time without any prior notice. It also reserves the right to change the design and specifications of its equipment or any related documentation at any time. The end user is not entitled to upgrades or refunds resulting from these changes.**

### Updates

These Terms and Conditions were last updated on May 2nd, 2016.

For questions or assistance, call SKYFOOD EQUIPMENT Toll Free: **1-800-503-7534**, or visit the Customer Service section at [www.skyfood.us](http://www.skyfood.us).

#### TERMS AND CONDITIONS OF SALE

##### Terms of Sale

Purchase of any products sold by SKYFOOD shall be subject to and expressly limited by the terms and conditions contained herein. No changes to, waiver of, or addition to any of these terms and conditions shall be effective unless agreed to in writing and signed by SKYFOOD. Buyer acknowledges and agrees that these terms and conditions supersede the terms and conditions of any purchase order or other documentation used by Buyer and, except for delivery and billing addresses, and quantities prices and items ordered, any conflicting or additional terms are void and have no effect, but that Buyer may place orders by use of purchase orders and other documentation for its convenience purposes only. Notwithstanding the foregoing, SKYFOOD reserves the right at any time to amend these terms and conditions, and Buyer shall be deemed to accept such amended terms and conditions by ordering products herein offered after the date of such amendment. Additional special terms and conditions of SKYFOOD may be applicable with respect to certain products.

##### Orders Acceptance

All orders from Buyers, whether solicited and written by either a SKYFOOD EQUIPMENT, LLC ("SKYFOOD") Sales Representative, distributor or dealer, are deemed offerings to purchase until accepted by SKYFOOD. SKYFOOD reserves the right to accept orders in full or in part. Acceptance may be either by written confirmation or shipment of the order, in full or in part.

##### Shipping

TERMS – All prices are FCA (Free Carrier) shipping point. Unless express instructions in writing are received from the Buyer, SKYFOOD has complete freedom in choosing the means, route and procedure to be followed in the handling, transportation and delivery of the goods. SKYFOOD will advance the shipping costs on behalf of the Buyer and charge it accordingly. **SKYFOOD shall under no circumstances be liable for any loss, damage, concealed damage, expense or delay of goods for any reason whatsoever when said goods are in the custody, possession or control of third parties selected by SKYFOOD to forward, enter, clear, transport, or render other services with respect to such goods. Please, inspect your unit upon arrival at the destination and report any transit damage to SKYFOOD and to the shipping company, in order to initiate a claim with the latter. Claims must be reported to the transportation company within fifteen (15) days as of the date of the shipping.**

##### Free Shipping

Orders of \$3,500.00 or more, with a minimum of 2 pieces (mixed or matched), shipped to the same address in the continental United States will have free shipping.

##### Rush Order

Rush order, when available and shipped to the same address in the continental United States, is subject to a "Rush Order Fee", in the amount of \$30.00. Please check lead times prior to ordering. If the due date is not met, the "Rush Fee" will be refunded.

##### Tax Information

Any tax, duty, custom or other fee of any nature imposed upon the products, their sale, transportation, delivery, use or consumption shall be paid by Buyer in addition to the price quoted or invoiced. If SKYFOOD is required to prepay any such tax or fee, Buyer will reimburse SKYFOOD. Buyer must provide SKYFOOD with a resale/exemption certificate in order to avoid the withholding of applicable taxes.

##### Interest

Past due balances are subject to a interest charge of 1.5% per month or the highest rate permitted by law, whichever is lower, until paid.

##### Internet Minimum Advertised Pricing - IMAP

Our IMAP pricing policy is intended for consumers to purchase from internet dealers and reseller websites based on loyalty and customer care expectations. This policy is effective as of the effective date stated below, and supersedes all previous Minimum Advertised Pricing – MAP policies related to SKYFOOD products as of that date. This IMAP policy shall work under the following guidelines:

##### Products:

The Internet Minimum Advertised Price for all SKYFOOD products can be found on our current Price List.

This IMAP applies only to the advertising and sales of SKYFOOD products which are sold to U.S. customers in the United States via the internet.

This IMAP policy is not applicable to: 1) Any physical store location, 2) Any email newsletters sent to your customer database, 3) In print publications or on any other media.

##### Procedures:

You can choose to advertise and sell, at any price, any SKYFOOD product on the internet. SKYFOOD will not control advertising and selling prices on the internet.

##### - Advertising and/or Selling below IMAP Price:

It shall be a violation of this policy to advertise and sell or offer for sale a SKYFOOD product on the internet at a sales price below the internet minimum advertise price ("the IMAP"). Repeatedly re-pricing due to IMAP prices breaches by other internet dealers and reseller websites is not an acceptable justification for violation of this policy.

Sales Price shall not include the cost of shipping or tax. In order to avoid any doubt, customers may offer free shipping to end users, without impacting this policy.

SKYFOOD reserves the right to suspend the enforcement of this policy for certain products, as and when SKYFOOD in its sole discretion, deems appropriate (e.g. product closeouts, specials, etc.).

##### - Prohibited Advertising Methods:

SKYFOOD has written this policy in an effort to protect and communicate the expectations for the internet dealers and reseller websites. Therefore, SKYFOOD considers any of the following to be damaging to our brand and thus are not permitted by internet dealers and reseller websites that use our brand for advertising:

- Advertising SKYFOOD products on third party internet dealers and reseller websites at a price that is below the IMAP Price.
- Using split screen, side by side, or pop-up advertising to advertise any similar product other than SKYFOOD's in conjunction with offering a SKYFOOD product for sale.

### 3. SLICING

The frozen meat should be thawed for several hours to make the outer and inner temperature the same after taken out of the refrigerator. It is easier to slice when the temperature of the meat is at 23 F (–5º) to 46 F (8º).

Usually when pressing the meat with fingers, tenderness can be felt in the center, so the temperature of the meat is near the above temperatures.

### 4. SHARPENING THE BLADE

1. The blade needs to be sharpened frequently. Before sharpening, the smear on the blade should be wiped out. Prevent the smear dirtying the grinding wheel. Once dirtied. It should be cleaned with cleanser and a brush.

2. Loosen the fixing handle of the sharpener cover, lift up the cover and turn it for the grinding wheel and place it back onto the blade. And then fix the handle.

3. Switch the machine on. Press the handle of the grinding wheel on the back of the blade. Generally speaking sharpen the blade for 20-40 seconds.

4. Turn off the power after sharpening is done and turn the sharpener cover to its original place.

### 5. MAINTENANCE AND CLEANING

1. Inspection and preparation before use:

A. Every active part should be filled with small amount of lubricant regularly, especially the round and square axes under the operating frame, to reduce the damage caused by extended work.

B. Please make sure the blade is sharp.(If it is not sharp, please refer to Sharpening the blade).

C. Pay attention to the safety items. Especially the ground wire, before operating the machine.

D. After switching on it is better to let the machine work empty for 1-2 minutes to see if there is any abnormality (like: abnormal noise, smell).

E. When cleaning the machine, please protect the power part and the working part from water to avoid electricity leaking.

## 6. TROUBLESHOOTING

If there is any trouble when machine works, please make sure the following steps are taken:

TROUBLE	REASONS	MEASURES
The machine doesn't work or work with low speed.	<ul style="list-style-type: none"> <li>- The electrical outlet doesn't connect well.</li> <li>- The wire drops.</li> <li>- The voltage is not steady.</li> </ul>	<ul style="list-style-type: none"> <li>- Confirm the connection of the electrical outlet.</li> <li>- Confirm if every part is connected well, or if the wire drops.</li> <li>- Keep the voltage steady.</li> </ul>
The effect of the Slicing is not good.	<ul style="list-style-type: none"> <li>- The time of thawing is so short that the frozen meat is too hard.</li> <li>- The blade is not sharp enough.</li> <li>- The meat supplying device is not lubricated enough.</li> <li>- The meat-nipping device nips the meat too hard.</li> </ul>	<ul style="list-style-type: none"> <li>- Refer to the introduction of the meat slicing.</li> <li>- Refer to Sharpening the blade.</li> <li>- Fill in small amount of lubricant in the blade pole, but rap oil and bean of oil are not allowed. It is better to clean the device with dissolved liquid.</li> </ul>
The speed of the blade is slow when it works.	<ul style="list-style-type: none"> <li>- The wheel belt is loose.</li> </ul>	<ul style="list-style-type: none"> <li>- Lie down the machine and then strain the adjusting pole beside the motor.</li> </ul>

## 8. ELECTRICAL DIAGRAM

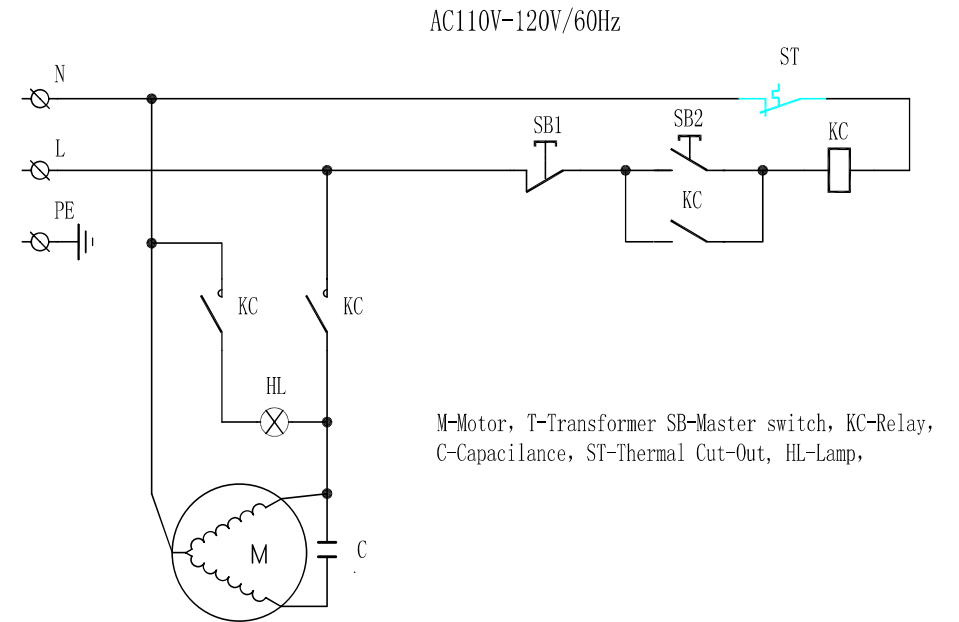

NUMBER	DESCRIPTION
58	Grinding wheel pin
59	Sharpener cover
60	Sharpener knob
61	Sharpener support pin
62	Sharpener components seat
63	Grinding wheel pin
64	Upper button of the sharpener pin
65	Power cord
66	Button mulch
67	Switch
68	Relay
69	Spring
70	Sharpener module (one set)

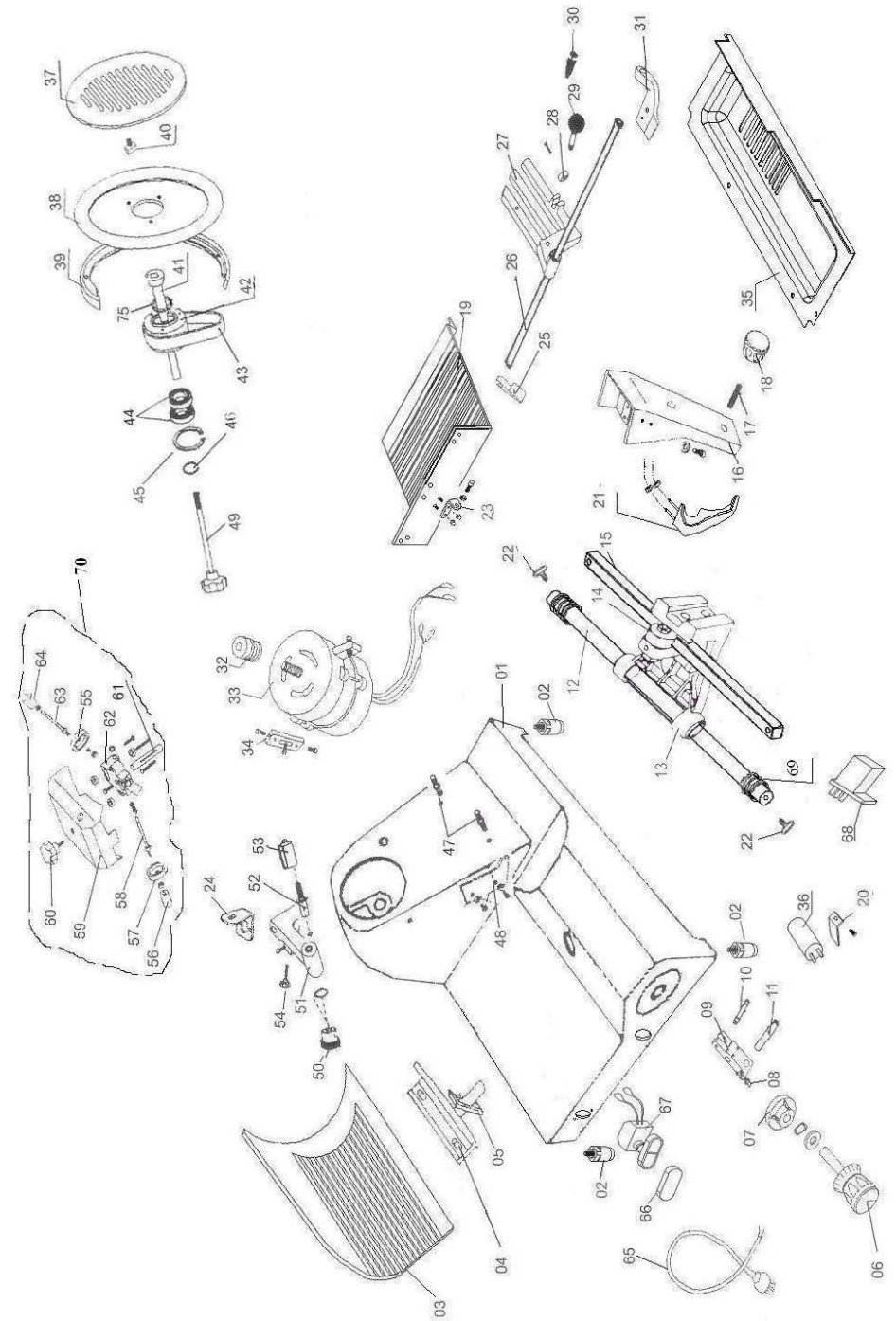

## 7. 312EC1 MODEL 12" HEAVY DUTY SLICER

NUMBER	DESCRIPTION
01	Base
02	Feet
03	Portable partition
04	Fulcrum bearing seat
05	Cover board
06	Adjusting knob
07	Cam
08	Slider pin
09	Slider
10	Eccentric shaft of slider
11	Sliding axle
12	Bracket sliding bar
13	Bracket
14	Bracket bearing
15	Square shaft
16	Pallet holder
17	Bracket fixing bolt
18	Bracket knob
19	Food tray
20	Capacitor retainer
21	Arc-shaped handle
22	Head screw
23	Aluminum hanging
24	Blade guarding support
25	Front block of the fixing arm axle
26	Fixing arm axle
27	Meat pressing plate
28	Fixing arm pulley

NUMBER	DESCRIPTION
29	Sphere knob
30	Fixing arm knob
31	Rear block of fixing arm axle
32	Motor pulley
33	Blade Motor
34	Motor pressure plate
35	Bottom plate
36	Capacitor
37	Blade guarding disc
38	Blade
39	Blade guard ring
40	Square-head nut of blade guard disc
41	Pulley axle
42	Belt pulley of the blade
43	Belt TB2-420A
44	Bearing 6204
45	Big retainer ring
46	Small retainer ring
47	Guard ring bolt
48	Meat scraper
49	Tension rod or protection plate
50	Adjusting knob
51	Sharpener support
52	Adjusting screw
53	Supporting shoe
54	Sharpener locking knob
55	Fine grinding wheel
56	Upper button of the sharpener pin
57	Crude grinding wheel