



YOU CAN TRUST



YOU CAN TRUST

## INSTRUCTIONS MANUAL



Skyfood Equipment LLC

**OFFICE**

175 SW 7th Street - Suite # 2416  
Miami, FL 33130

**1-800-503-7534 | 305-868-1603**

UG0175 - INGLÊS

Data de Correção: 09/07/2014

- BESIDES THIS EQUIPMENT, A COMPLETE RANGE OF OTHER PRODUCTS ARE MANUFACTURED, CONSULT OUR DEALERS  
- DUE TO THE CONSTANT IMPROVEMENTS INTRODUCED TO OUR EQUIPMENTS, THE INFORMATION CONTAINED IN THE PRESENT  
INSTRUCTION MANUAL MAY BE MODIFIED WITHOUT PREVIOUS NOTICE.

[www.skyfood.us](http://www.skyfood.us)

SLICER  
**SSI-12**





1.1 Technical Characteristics

TABLE 01

CHARACTERISTICS	UNIT	SSI-12
Voltage	V	120
Frequency	Hz	60
Power Rating	W	270
Thickness Control	mm	0 - 14
A	in	6
B	in	9
C	in	8.6
D	in	8
E	in	17
F	in	16
G	in	20
H	in	19
I	in	25
Blade Diameter	in	11
Net Weight	kg	28.6
Shipping Weight	kg	33

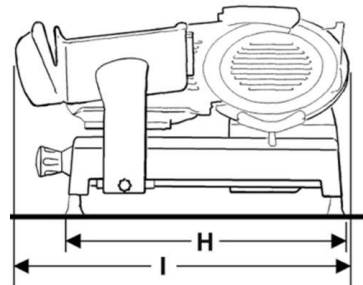
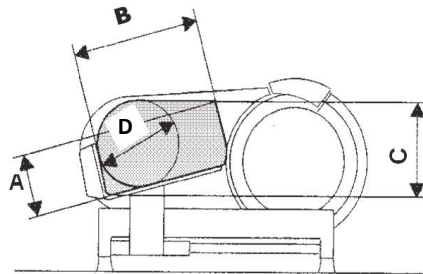
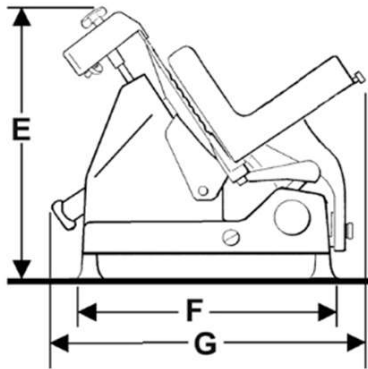

Warranty Registration



Questions about how to complete this form?  
 Call 1-800-503-7534 / 305-868-1603  
 Return completed form to:  
 SKYFOOD EQUIPMENT LLC  
 11900 Biscayne Blvd. Suite 616  
 North Miami, FL 33181 - USA  
 Or fax form to:  
 786 522 6765

User Details

Contact Person: \_\_\_\_\_

Business type:

- |                                                                        |                                                                           |
|------------------------------------------------------------------------|---------------------------------------------------------------------------|
| <input type="checkbox"/> Bakery and Bagel Operations                   | <input type="checkbox"/> Mass Merchandiser with Grocery                   |
| <input type="checkbox"/> Bakery (Associated with Restaurant)           | <input type="checkbox"/> Mass Merchandiser with NO Grocery                |
| <input type="checkbox"/> Baking Center                                 | <input type="checkbox"/> Meat Packer and Purveyor                         |
| <input type="checkbox"/> Business and Industry In-House Fooding        | <input type="checkbox"/> Other Business that prepares or serves food      |
| <input type="checkbox"/> Butcher                                       | <input type="checkbox"/> Other Business that sells but doesn't serve food |
| <input type="checkbox"/> Catering                                      | <input type="checkbox"/> Pizzeria (Direct In / Carry-Out)                 |
| <input type="checkbox"/> Club Store                                    | <input type="checkbox"/> Restaurants (Independent / Chain)                |
| <input type="checkbox"/> Convenience Store                             | <input type="checkbox"/> School                                           |
| <input type="checkbox"/> Country Club                                  | <input type="checkbox"/> Steakhouse / Cafeteria                           |
| <input type="checkbox"/> Delicatessen (Chain / Restaurant)             | <input type="checkbox"/> Supermarket / Grocery                            |
| <input type="checkbox"/> Delicatessen (Independent and Non-Restaurant) | <input type="checkbox"/> Tractor Park                                     |
| <input type="checkbox"/> Food Store                                    | <input type="checkbox"/> University / College                             |
| <input type="checkbox"/> Government                                    | <input type="checkbox"/> Winery / Winery                                  |
| <input type="checkbox"/> Hospital                                      | <input type="checkbox"/> Warehouse Clubs                                  |
| <input type="checkbox"/> Lodging                                       | <input type="checkbox"/> Wholesale Baking Operation (Non-Institutional)   |

Company Name: \_\_\_\_\_

Address: \_\_\_\_\_

City: \_\_\_\_\_

State: \_\_\_\_\_

Zip Code: \_\_\_\_\_

Phone: \_\_\_\_\_

Fax: \_\_\_\_\_

E-mail: \_\_\_\_\_

Web page: \_\_\_\_\_

I would like to join the Mail List.

I would like to join the E-mail List.

Product Details

Product Commercial Item: \_\_\_\_\_

This Product Commercial Item can be found on the machine's Product Identification Label.

Serial Number: \_\_\_\_\_

Confirm Serial Number: \_\_\_\_\_

This information, the Product Identification, can be found on the machine's Product Identification Label.

Proof of Purchase:  Yes  
 No

Purchased On: \_\_\_\_\_ (mm / dd / yyyy)

Purchased From: \_\_\_\_\_

Company Name

\* Indicates required field.

\*\* Indicates required field, not mandatory by Fax.

to SKYFOOD's facility or to a Service Company. Mileage or travel time will NOT be paid. SKYFOOD offers a limited on-site warranty for products ONLY held at commercial facilities, whose net weight exceeds seventy (70) lbs., provided they are installed in a location that is within a thirty (30) mile radius of a Service Company. **End Users are responsible for all extra travel and mileage rates.** In this case, warranty services will be provided during regular business hours.

**This product will be replaced or repaired under warranty, for a period of (1) year, beginning from the date of purchase by the original purchaser/user ("End User"), or eighteen (18) months from the date of shipment from SKYFOOD's warehouse, whichever expires first.**

Accessories will be replaced or repaired under warranty, for a period of (30) days, beginning from the date of purchase by the original purchaser/user ("End User"), or eighteen (18) months from the date of shipment from SKYFOOD's warehouse, whichever expires first.

This warranty shall not take effect until a properly completed and executed **WARRANTY REGISTRATION** form has been received by SKYFOOD EQUIPMENT, LLC, within thirty (30) days from the date of purchase. The **WARRANTY REGISTRATION** is available either in the Instruction Manual of every Product or at SKYFOOD's website [www.skyfood.us](http://www.skyfood.us). The End User must fill out the **WARRANTY REGISTRATION** form and send it to SKYFOOD according to the instructions posted on the referred website. **Failure to do so will VOID the warranty.**

**No extended warranties for third party products. There are no other express warranties or conditions other than the one offered by each manufacturer for products sold by SKYFOOD, not under the SKYFOOD brand.**

For questions or assistance, do not return the product or accessories to the store, please call Toll Free 1-800-503-7534, or visit the Customer Service section at [www.skyfood.us](http://www.skyfood.us). For faster service please have the items name, serial number, and proof of purchase for the operator to assist you.

**SKYFOOD reserves the right to change the terms of its limited warranty at any time without any prior notice. It also reserves the right to change the design and specifications of its equipment or any related documentation at any time. The end user is not entitled to upgrades or refunds resulting from these changes.**

#### **Updates**

These **Terms and Conditions** were last updated on May 2<sup>nd</sup>, 2016.

## **2. GENERAL NOTES AFTER THE RECEIPT OF THE MACHINE**

The machine is delivered in its packing.

After the receipt of the machine, check that the packing is intact and that the slicer corresponds with the model in demand.

**Standard 2002/96/CE WAEE: Give the machine back to the manufacturer to manage its disposal according to the rules.**

### **2.1 Machine identification**

In any communication with the manufacturing company always quote the serial number indicated on the identification label of the machine.

### **2.2 Installation**

The slicer must be placed on a plane, horizontal, antiskid and stable surface, fit for carrying its weight. The recommended height of the worktop is about 800 mm. Check there are no obstacles for the product holder stroke.

### **2.3 Preliminary cleaning**

Clean off the protective oil from the slicer.

### 3. ELECTRICAL SUPPLY

Check that the voltage corresponds to the label data.

- 1 - Connect the machine to the socket.
- 2 - Check that the blade cover fastener handle is tight screwed.
- 3 - Check that the blade sharpener is lowered and the protective cover is closed.
- 4 - Press the ON pushbutton to start the blade rotation.
- 5 - The blade must rotate in the direction indicated by the arrow



#### SKYFOOD EQUIPMENT LLC - SERVICE

For questions or assistance, call SKYFOOD EQUIPMENT Toll Free: 1-800-503-7534, or visit the Customer Service section at [www.skyfood.us](http://www.skyfood.us)

#### SKYFOOD'S LIMITED WARRANTY

Unless otherwise specified, new SKYFOOD products, excluding accessories, sold by SKYFOOD EQUIPMENT, LLC. ("SKYFOOD"), for use only in the continental United States (collectively, "Products" or singularly, "Product"), are warranted to be free from defects in materials and workmanship for a period of one (1) year from the date of purchase by the original purchaser/user ("End User"), or eighteen (18) months from the date of shipment from SKYFOOD's warehouse, whichever expires first. Several new products and accessories may be warranted for a period other than one (1) year while others may be subject to travel limitations, as specified on the products Instruction Manual. **Proof of purchase must be presented; if not this warranty will be VOID.** No warranty is given or implied to a subsequent transferee or any other third party. This warranty is expressly conditional upon SKYFOOD being notified of any defects in materials or workmanship within five (5) days of its occurrence, within the warranted time period. If a notice of a claim under this warranty is timely made by the End User, SKYFOOD or a SKYFOOD's designated service company ("Service Company"), will repair or replace the Product, at SKYFOOD's discretion, subject to the additional conditions hereinafter described.

This warranty shall not apply if damage occurs from improper installation or maintenance performed by an unauthorized service company ("Service Company"), wrong voltage, nor to the extent that Products or parts have been used other than in conformance with operating and maintenance instructions, subjected to misuse or abuse or damaged by accident, acts of God, abnormal use, stress or any other matter unrelated to SKYFOOD, and beyond its reasonable control. **This warranty does NOT cover service labor and travel to perform adjustments on products and/or accessories.** In addition to wear and tear of certain items, such as, but not limited to; glass parts, blades, stones, chopper cutting knives, plates, slicing knives, cutting disc, gaskets, oil changes, sealing tape, heat seal wires, worm gears, self-lubricating bushings, carbon brushes for electric motors, and other parts expendable by nature and that need to be replaced frequently. **Electrical components are subject to natural wear and tear, and are NOT covered by this warranty. THIS WARRANTY EXCLUDES ALL ORAL, STATUTORY, EXPRESS OR IMPLIED WARRANTIES WHICH MAY BE APPLICABLE TO SKYFOOD, INCLUDING, BUT NOT LIMITED TO, ANY IMPLIED WARRANTY OF MERCHANTABILITY AND FITNESS FOR PARTICULAR PURPOSE.** Under no circumstances shall SKYFOOD be liable for loss of use, revenue or profit or for incidental or consequential damages. SKYFOOD shall under no circumstances be liable for any loss, damage, concealed damage, expense or delay of goods for any reason when said goods are in the custody, possession or control of third parties selected by SKYFOOD to forward, enter, clear, transport, or render other services with respect to such goods. The sole and exclusive remedy for breach of any warranty is limited to the remedies provided in the paragraph above.

All products held at non-commercial facilities or domiciles, must be taken or shipped, shipping charges prepaid, either to SKYFOOD's facility or a SKYFOOD's designated service company ("Service Company"). Products held at commercial facilities and weighing less than seventy (70) lbs. must be taken or shipped, shipping charges are prepaid, either

## 9. ELECTRICAL DIAGRAM

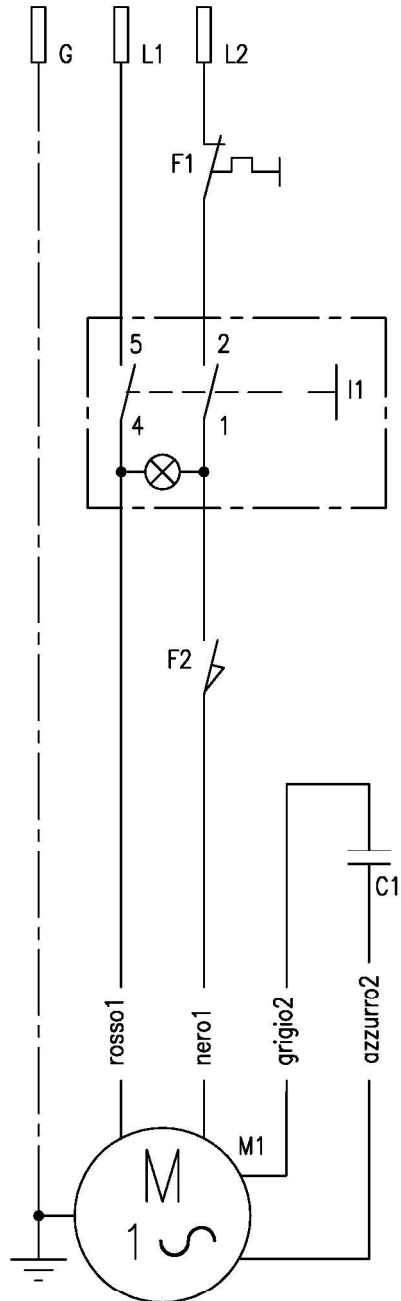

## 4. DEFINITIONS

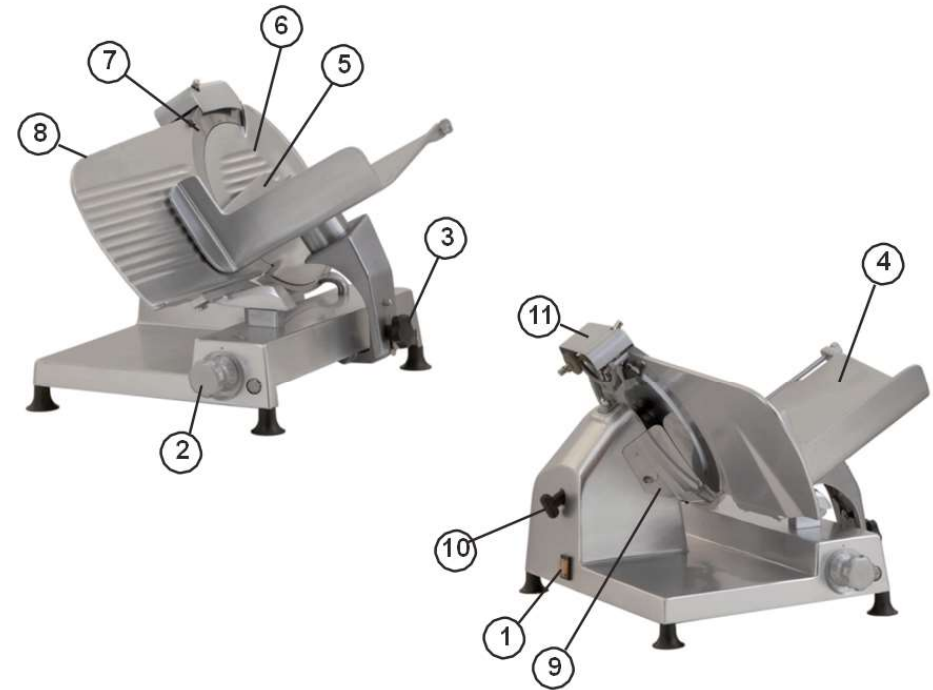

- 1 - Control Pushbuttons
- 2 - Slice Thickness Control
- 3 - Product Holder Clamping Handle
- 4 - Product Holder
- 5 - Pusher
- 6 - Blade Cover
- 7 - Blade
- 8 - Slice Thickness Plate
- 9 - Slice Deflector
- 10 - Blade Cover Fastener Handle
- 11 - Integrated Blade Sharpener Device

## 5. SLICER FUNCTIONING AND USE

**WARNING**  
**The following products are not sliceable:**  
- Inedible products  
- Products with bones  
- Frozen products

Check that the slicer is off and position the slice thickness control on zero.

### 5.1 How to load the product to cut

- 1 - Place the product to cut against the product holder and the thickness plate sides.
- 2 - Lay the last slice device on the product to cut, far from the slice thickness plate. The product is fed to the slice thickness plate by gravity, this makes the cut easier.
- 3 - Rotate the slice thickness control onto the cutting thickness you wish.
- 4 - Press the ON pushbutton to start the blade.
- 5 - At constant speed feed the product holder to the blade stroke end then return to the operator and repeat the operation.
- 6 When the work is over, pull the product holder towards the operator, press the "0" button to turn the blade off and rotate the slice thickness control on zero.

### 5.2 How to load short products (last slice)

Check that the slicer is off and position the slice thickness control on zero.

**WARNING**  
**Do not use your hands to push the products towards the blade.**

- 1 - Place the product to be cut against the wall of the product holder and the slice thickness plate.
- 2 - Push the goods against the slice thickness plate using the last slice device.
- 3 - Rotate the slice thickness control onto the cutting thickness you wish.

## 8.7 Warning

Electrical or mechanical maintenance has to be undertaken by qualified personnel. The person in charge of maintenance has to be sure that the machine is under TOTAL SAFETY conditions when working.

signs of wearing.

When checking the tension of belts or chains DO NOT insert your fingers between belts and pulleys, nor between the chains and gears.

Check protections and safety devices to make sure they are working properly.

## 8.4 Operation

### 8.4.1 Warnings

Do not use the machine with long hair that could touch any part of the machine. This might lead to a serious accident. Tie your hair up well and/or cover it with a scarf.

Only trained or skilled personnel shall operate this machine.

Never touch turning parts with your hands or any other way ,

NEVER operate the machine without any original safety devices under perfect conditions.

## 8.5 After Finishing The Work

### 8.5.1 Precautions

Always TURN THE MACHINE OFF before cleaning by removing the plug from the socket.

Never clean the machine unless it has come to a complete stop.

Put all the components back to their functional positions before turning the machine ON again.

Check the level of oil.

Do NOT insert your fingers in between belts and pulleys nor chains and gears.

## 8.6 Maintenance

### 8.6.1 Danger

Any maintenance with the machine in working situation is dangerous. TURN IT OFF BY PULLING THE PLUG OFF THE SOCKET DURING MAINTENANCE.

#### **IMPORTANT**

**Always remove the plug from the socket in any emergency situation.**

4 - Press the ON pushbutton to start the blade.

5 - At constant speed feed the product holder to the blade stroke end then return to the operator and repeat the operation.

6 - When the work is over, pull the product holder towards the operator, press the "0" button to turn the blade off and rotate the slice thickness control on zero.

## 6. BLADE SHARPENING

Whenever the cut is not satisfactory, sharp the blade. The time interval between a sharpening and the following depends on the intensity of use of the slicer and on the kind of food you cut.

Replace the blade when the diameter becomes 10 mm less than the nominal diameter. For the replacement, ask the assistant service closest to you.

### WARNING

**The replacement of the blade is a dangerous operation.  
If the sharpening is not appropriate, replace both grindstones.  
Contact a customer service.**

1. Clean the blade removing any greasy residue.
2. Make sure that the machine is off.
3. Rotate the slice thickness control to zero to make sure that the blade is protected by the slice thickness plate.
4. Slip off completely the sharpener and spin it 180 degrees.
5. Put the sharpener device.

Push the green button to start the machine.

**7. Sharpening:** Press the A sharpening wheel button for about 10-15 seconds, then press simultaneously also the B grinding stone button for two seconds. Contemporaneously loosen the two buttons.

8. Press the red stop pushbutton.

Lift and rotate 180 degrees the sharpener and reallocate it into its initial position.

### Cleaning of the grinding wheels

To obtain an excellent sharpening the grinding wheel must always be clean. Remove dirt and grease with alcohol and the supplied special brush.

- \* Avoid mechanical shocks, once they may cause damages or bad functioning.
- \* Avoid water, dirt or dust contact to the mechanical and electrical components of the machine.
- \* DO NOT change the standard characteristics of the machine.
- \* DO NOT remove, tear off or maculate any safety or identification labels stuck on the machine. If any labels have been removed or are no longer legible, contact your nearest dealer for replacement.

## 8.2 Safety Procedures and Notes before Switching the Machine ON

### IMPORTANT

**Carefully read ALL INSTRUCTIONS of this manual before turning the machine ON.  
Be sure to well understand all the information contained in this manual. If you  
have any question contact your supervisor or your nearest Dealer.**

#### 8.2.1 Danger

An electric cable or electric wire with damaged jacket or bad insulation might cause electrical shocks as well as electrical leak. Before use, check the conditions of all wires and cables.

#### 8.2.2 Advices

Be sure to well understand all the information contained in this manual. Every operation function or procedure has to be thoroughly clear.

Before using any commands (switch, buttons, lever), be sure it is the correct one. In case of doubt, consult this manual.

#### 8.2.3 Precautions

The electric cable has to be compatible with the power required by the machine.

Cables touching the floor or close to the machine need to be protected against short circuits.

The oil reservoirs have to be filled until the indicated level. Check and refill if necessary.

## 8.3 Routine Inspection

#### 8.3.1 Advice

When checking the tension of the belts or chains, DO NOT insert your fingers between the belts and the pulleys and nor between the chain and the gears.

#### 8.3.2 Precautions

Check the motor and sliding or turning parts of the machine in case of abnormal noises. Check the tension of the belts and chains and replace the set when belts or chains show

## 8. GENERAL SAFETY PRACTICES

### IMPORTANT

If any recommendation is not applicable to your equipment, please ignore it.

The following safety instructions are addressed to both the operator of the machine as well as the person in charge of maintenance.

The machine has to be delivered only in perfect conditions of use by the Distributor to the user. The user shall operate the machine only after being well acquainted with the safety procedures described in the present manual. **READ THIS MANUAL WITH ATTENTION.**

### 8.1 Basic Operation Practices

#### 8.1.1 Dangers

Some areas of the electric device have parts that are connected or have parts connected to high voltage. These parts when touched may cause severe electrical shocks or even be lethal.

Never touch manual commands such as switches, buttons, turning keys and knobs with your hands wearing wet clothes and/or wet shoes. By not following these instructions operator could be exposed to severe electrical shocks or even to a lethal situation.

#### 8.1.2 Warnings

- \* The operator has to be well familiar with the position of ON/OFF Switch to make sure the Switch is easy to be reached when necessary.
- \* Before any kind of maintenance, physically remove plug from the socket.
- \* Provide space for a comfortable operation thus avoiding accidents.
- \* Water or oil spilled on the floor will turn it slippery and dangerous. Make sure the floor is clean and dry.
- \* Before using any commands (switch, buttons, lever), be sure it is the correct one. In case of doubt, consult this manual.
- \* Never touch any manual commands (switch, buttons, lever) unadvisedly.
- \* If any work is to be made by two or more persons, coordination signs will have to be given for each operation step. Every step of the operation shall be taken only if a sign has been made and responded.

#### 8.1.3 Advices

- \* In case of power shortage, immediately switch the machine off.
- \* Use recommended or equivalent lubricants, oils or greases.

## 7. MAINTENANCE

Disconnect the plug from the power point and take the slice thickness control on zero. We advise to wear protective gloves during all the cleaning and maintenance operations.

### Electric cable check

Periodically check the electric cable wear.

### Spare parts

In case of parts replacement, ask only original spare parts.

### 7.1 Cleaning

If you do not use the machine for long time, always carry out a deep cleaning of the machine before using it.

For the cleaning of all the open parts use a dampen cloth.

### WARNING

Do not use water jet

### Components Removal

### DANGER

During the cleaning operations be careful: danger of accident

### Product holder

- 1 - Position on zero the slice thickness control.
- 2 - Loosen up completely the product holder clamping handle rotating it counterclockwise.
- 3 - Pull the product holder towards the operator
- 4 - Lift the product holder slipping it off from its support.
- 5 - Clean the product holder.

### IMPORTANT

The slice thickness control is clamped on zero.

### Slice deflector

6 - Loosen the fixing screws and remove the slice deflector.

### Blade cover

7 - Loosen the blade cover fastener handle rotating it counterclockwise.

8 - Push the handle in the direction of the blade.

9 - Lift the blade cover.

#### ATTENTION

Once removed the blade cover, an interlocking device stops the rotation of the blade.

### Blade cleaning

#### DANGER

During the cleaning of the blade, be careful of any accidental contact with the blade.

10 - Mop up the front side of the blade with a dampen cloth and move slowly from the centre to the edge of the blade, as shown by the arrow in the picture.

11 - Clean in the same way the back side of the blade.

12 - Dry with a cloth both sides of the blade.

13 - After cleaning, fix the blade cover.

14 - Insert the fastener and screw to block the blade cover.

Clean all the pieces in warm water and washing-up liquid. Rinse them with hot water and dry them.

Assemble the machine following in reverse the procedure described above.

### 7.3 Guides lubrication

This operation must be performed after cleaning the slicer or whenever the sliding is difficult. Use oil SHELL ONDINA 15 or ESSO MARCOL 82.

### Lubrication of the guide bar of the product holder:

1 - Drop some oil on the bar

2 - Let the last slice device slide on the guide bar

### Lubrication of the guide bar of the product holder carriage:

1 - Push the product holder towards stroke end

2 - Lift the slicer

3 - Drop some oil on the bar

4 - Place the slicer on the work top, push the product holder to and front.

