



YOU CAN TRUST



YOU CAN TRUST

INSTRUCTIONS MANUAL



Skyfood Equipament LLC

OFFICE

175 SW 7th Street - Suite # 2416
Miami, FL 33130

1-800-503-7534 | 305-868-1603

UG0172 - INGLÊS

Data de Correção: 27/06/2014

MEAT GRINDER
SMG12

- BESIDES THIS EQUIPMENT, A COMPLETE RANGE OF OTHER PRODUCTS ARE MANUFACTURED, CONSULT OUR DEALERS
- DUE TO THE CONSTANT IMPROVEMENTS INTRODUCED TO OUR EQUIPMENTS, THE INFORMATION CONTAINED IN THE PRESENT
INSTRUCTION MANUAL MAY BE MODIFIED WITHOUT PREVIOUS NOTICE.

www.skyfood.us

SUMMARY

1. INTRODUCTION	3
1.1 Technical Characteristics	3
1.2 Features.....	4
2. LOCATION	4
3. OPERATION.....	5
4. MAINTENANCE	6
5. CLEANING	6
6. GENERAL SAFETY PRACTICES.....	7
6.1 Basic Operation Practices.....	7
6.2 Safety Procedures and Notes before Switching the Machine ON	8
6.3 Routine Inspection.....	8
6.4 Operation	9
6.5 After Finishing The Work.....	9
6.6 Maintenance	9
6.7 Warning.....	10
7. TROUBLE SHOOTING.....	11
8. ELECTRIC DIAGRAM	12
SKYFOOD EQUIPMENT LLC - SERVICE	13
SKYFOOD'S LIMITED WARRANTY	13

Warranty Registration



Questions about how to complete this form?
Call 1-800-503-7534 / 305-868-1603
Return completed form to:
SKYFOOD EQUIPMENT LLC
11900 Biscayne Blvd, Suite 616
North Miami, FL 33181 - USA
Or fax form to:
786 522 6765

User Details

Contact Person: _____

Business type:

- | | |
|------------------------------------------------------------------------|---------------------------------------------------------------------------|
| <input type="checkbox"/> Bakery and Bagel Operations | <input type="checkbox"/> Mass Merchandiser with Grocery |
| <input type="checkbox"/> Bakery (Associated with Restaurant) | <input type="checkbox"/> Mass Merchandiser with NO Grocery |
| <input type="checkbox"/> Baking Center | <input type="checkbox"/> Meat Packer and Processor |
| <input type="checkbox"/> Business and Industry In-House Feeding | <input type="checkbox"/> Other Business that prepares or serves food |
| <input type="checkbox"/> Butcher | <input type="checkbox"/> Other Business that sells but doesn't serve food |
| <input type="checkbox"/> Catering | <input type="checkbox"/> Pican (Dine In / Carry Out) |
| <input type="checkbox"/> Chain Stores | <input type="checkbox"/> Restaurants (Independent / Chain) |
| <input type="checkbox"/> Convenience Store | <input type="checkbox"/> School |
| <input type="checkbox"/> Country Club | <input type="checkbox"/> Steaks and Cafeteria |
| <input type="checkbox"/> Delicatessen (Chain / Restaurant) | <input type="checkbox"/> Supermarket / Grocery |
| <input type="checkbox"/> Delicatessen (Independent and Non-Restaurant) | <input type="checkbox"/> Theme Park |
| <input type="checkbox"/> Food Store | <input type="checkbox"/> University / College |
| <input type="checkbox"/> Government | <input type="checkbox"/> Winery / Winery |
| <input type="checkbox"/> Hospital | <input type="checkbox"/> Warehouse Clubs |
| <input type="checkbox"/> Lodging | <input type="checkbox"/> Wholesale Baking Operations (Non-Institutional) |

Company Name: _____

Address: _____

City: _____

State: _____

Zip Code: _____

Phone: _____

Fax: _____

E-mail: _____

Web page: _____

I would like to join the Mail List.

I would like to join the E-mail List.

Product Details

Product Commercial Item: _____

The Product Commercial Item can be found on the machine's Product Identification Label.

Serial Number: _____

Confirm Serial Number: _____

This information, the Product Identification, can also be found on the machine's Product Identification Label.

Proof of Purchase: Yes
 No

Purchased On: _____ / _____ / _____ (mm / dd / yyyy)

Purchased From: _____

Company Name

* Indicates required field.

** Indicates required field, not mandatory by Fax.

shipping charges prepaid, either to SKYFOOD's facility or a SKYFOOD's designated service company ("Service Company"). Products held at commercial facilities and weighing less than seventy (70) lbs. must be taken or shipped, shipping charges are prepaid, either to SKYFOOD's facility or to a Service Company. Mileage or travel time will NOT be paid. SKYFOOD offers a limited on-site warranty for products ONLY held at commercial facilities, whose net weight exceeds seventy (70) lbs., provided they are installed in a location that is within a thirty (30) mile radius of a Service Company. **End Users are responsible for all extra travel and mileage rates.** In this case, warranty services will be provided during regular business hours.

This product will be replaced or repaired under warranty, for a period of (6) months, beginning from the date of purchase by the original purchaser/user ("End User"), or eighteen (18) months from the date of shipment from SKYFOOD's warehouse, whichever expires first.

Accessories will be replaced or repaired under warranty, for a period of (30) days, beginning from the date of purchase by the original purchaser/user ("End User"), or eighteen (18) months from the date of shipment from SKYFOOD's warehouse, whichever expires first.

This warranty shall not take effect until a properly completed and executed **WARRANTY REGISTRATION** form has been received by SKYFOOD EQUIPMENT, LLC, within thirty (30) days from the date of purchase. The **WARRANTY REGISTRATION** is available either in the Instruction Manual of every Product or at SKYFOOD's website www.skyfood.us. The End User must fill out the **WARRANTY REGISTRATION** form and send it to SKYFOOD according to the instructions posted on the referred website. **Failure to do so will VOID the warranty.**

No extended warranties for third party products. There are no other express warranties or conditions other than the one offered by each manufacturer for products sold by SKYFOOD, not under the FLEETWOOD by SKYMSSEN and SKYMSSEN brand.

For questions or assistance, do not return the product or accessories to the store, please call Toll Free 1-800-503-7534, or visit the Customer Service section at www.skyfood.us. For faster service please have the items name, serial number, and proof of purchase for the operator to assist you.

SKYFOOD reserves the right to change the terms of its limited warranty at any time without any prior notice. It also reserves the right to change the design and specifications of its equipment or any related documentation at any time. The end user is not entitled to upgrades or refunds resulting from these changes.

Updates

These **Terms and Conditions** were last updated on January 14th, 2014.

1. INTRODUCTION

The Meat Grinder is intended for medium-duty work in commercial food processing applications. Their exceptional reliability and attractive, compact designs make them ideal for any open kitchen and supermarket.

1.1 Technical Characteristics

TABLE 01

CHARACTERISTICS	UNIT	SMG12
Voltage	V	110
Frequency	Hz	60
Productivity	lb/h	260
Blade Speed	RPM	170
Power Rating	HP	1.5
Height	in	17"
Width	in	10"
Depth	in	17"
Net Weight	lb	66
Shipping Weight	lb	69

PICTURE 01

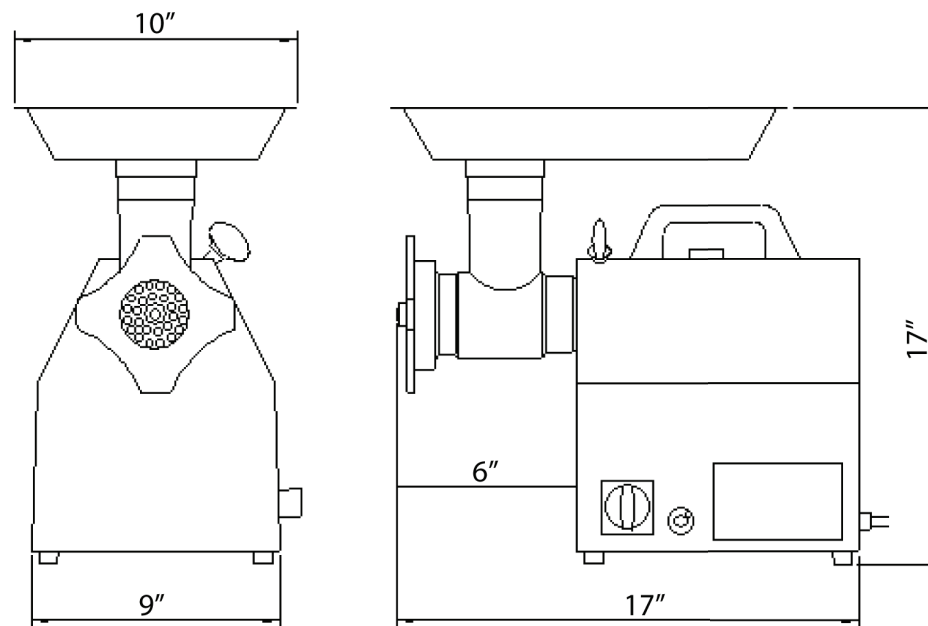

1.2 Features

1. Strict compliance with hygiene standard
2. Listed by ETL sanitation, conforms to NSF standard No.8
3. Reliable under the most demanding conditions
4. Energy-efficient motor and precision gear drive
5. FORWARD & REVERSE switch
6. Circuit breaker protect motor without overloading
7. Compact size, no sharp corners or seams
8. Attractive design suitable for any open kitchen and supermarket
9. Design for easy maintenance & Conforms to all safety standards
10. Powerful, energy-efficient motor
11. Easy-to-remove attachments and grinder head
12. Stainless Steel surface.

2. LOCATION

1. Placing the grinder on a smooth surface of table. Allowing working space large enough for feeding meat into the grinder chamber and maintenance.
2. Adequate local lighting should > 500 LUX

SKYFOOD EQUIPMENT LLC - SERVICE

For questions or assistance, call SKYFOOD EQUIPMENT Toll Free: **1-800-503-7534**, or visit the Customer Service section at www.skyfood.us.

SKYFOOD'S LIMITED WARRANTY

Unless otherwise specified, new **FLEETWOOD by SKYMSEN** and **SKYMSEN** products, excluding accessories, sold by SKYFOOD EQUIPMENT, LLC. ("SKYFOOD"), for use only in the continental United States (collectively, "Products" or singularly, "Product"), are warranted to be free from defects in materials and workmanship for a period of one (1) year from the date of purchase by the original purchaser/user ("End User"), or eighteen (18) months from the date of shipment from SKYFOOD's warehouse, whichever expires first. Several new products and accessories may be warranted for a period other than one (1) year while others may be subject to travel limitations, as specified on the products Instruction Manual. **Proof of purchase must be presented; if not this warranty will be VOID.** No warranty is given or implied to a subsequent transferee or any other third party. This warranty is expressly conditional upon SKYFOOD being notified of any defects in materials or workmanship within five (5) days of its occurrence, within the warranted time period. If a notice of a claim under this warranty is timely made by the End User, SKYFOOD or a SKYFOOD's designated service company ("Service Company"), will repair or replace the Product, at SKYFOOD's discretion, subject to the additional conditions hereinafter described.

This warranty shall not apply if damage occurs from improper installation or maintenance performed by an unauthorized service company ("Service Company"), wrong voltage, nor to the extent that Products or parts have been used other than in conformance with operating and maintenance instructions, subjected to misuse or abuse or damaged by accident, acts of God, abnormal use, stress or any other matter unrelated to SKYFOOD, and beyond its reasonable control. **This warranty does NOT cover service labor and travel to perform adjustments on products and/or accessories.** In addition to wear and tear of certain items, such as, but not limited to; glass parts, blades, stones, chopper cutting knives, plates, slicing knives, cutting disc, gaskets, oil changes, sealing tape, heat seal wires, worm gears, self-lubricating bushings, carbon brushes for electric motors, and other parts expendable by nature and that need to be replaced frequently. **Electrical components are subject to natural wear and tear, and are NOT covered by this warranty. THIS WARRANTY EXCLUDES ALL ORAL, STATUTORY, EXPRESS OR IMPLIED WARRANTIES WHICH MAY BE APPLICABLE TO SKYFOOD, INCLUDING, BUT NOT LIMITED TO, ANY IMPLIED WARRANTY OF MERCHANTABILITY AND FITNESS FOR PARTICULAR PURPOSE.** Under no circumstances shall SKYFOOD be liable for loss of use, revenue or profit or for incidental or consequential damages. SKYFOOD shall under no circumstances be liable for any loss, damage, concealed damage, expense or delay of goods for any reason when said goods are in the custody, possession or control of third parties selected by SKYFOOD to forward, enter, clear, transport, or render other services with respect to such goods. The sole and exclusive remedy for breach of any warranty is limited to the remedies provided in the paragraph above.

All products held at non-commercial facilities or domiciles, must be taken or shipped,

8. ELECTRIC DIAGRAM

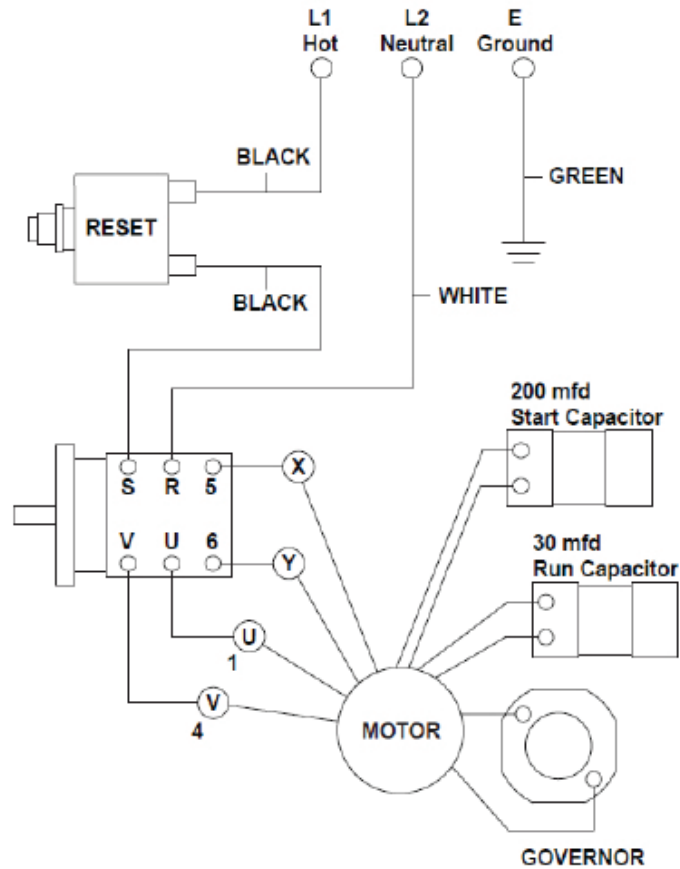

3. OPERATION

IMPORTANT:

Operator has to be a minimum of 18 years old to work with the grinders. The operator should be properly trained in accordance to the operation and care booklet.

IMPORTANT:

Before connecting your unit to your power supply, be sure your machine's electrical specifications, printed on the unit's nameplate, match those of your local power.

1. For first-time use, remove the grinder head and wash parts thoroughly. Reassemble according to the diagram included in these instructions.
2. Before grinding, tighten the thumbscrew counter-clockwise until secure. Do not use a tool or over-tighten.
3. The operator should wear the apron, glove and gauze mask on grinding for sanitation.
4. Clean the grinder and meat before grinding.
5. Prepare meat for grinding by removing all skin and bones. Then cut the meat into appropriately sized pieces for grinding.
6. Feed meat into the grinding chamber with the special meat pusher that was included with your machine. Never use finger, hands, or any other objects.
7. Clean and disinfect the grinder thoroughly after every-time using.
8. After use, disconnect the unit from the power supply and disassemble the head. Wash thoroughly to prevent contamination.

NOTE:

1. During grinding, meat should be discharged from the grinder smoothly. If the discharge is not smooth, or if it is in the form of a paste, the following causes and remedies should be considered.
2. Never defrost meat at room temperature and always marinate foods in the refrigerator to reduce risk of meat-borne illness.

4. MAINTENANCE

IMPORTANT

ALL MAINTENANCE WORK SHOULD BE DONE ONLY AFTER UNIT HAS BEEN DISCONNECTED FROM ELECTRICAL POWER AND GROUNDING.

Never use a metal or stiff brush to clean the grinder. Never clean the grinder with a water hose or any fluid pressure.

5. CLEANING

Always unplug the grinder from the power supply before cleaning. If the grinder is hard wired to the electrical outlet then the power should be turned off at the circuit breaker.

1. The grinder should be thoroughly cleaned daily.
2. DO NOT HOSE DOWN OR WASH THE GRINDER WITH A PRESSURE WASHER.
3. To clean the exterior of the mixer wipe with a damp cloth and mild food safe cleaning detergent.
4. Consider using paper towels to clean up machine surfaces. When done, throw away the towel. If you use cloth towels, wash them often in the hot cycle of your washing machine.
5. DO NOT touch the blade edges while cleaning.
6. The floor of working area should be kept dry after clean to avoid slipping.
7. Remove the grinder attachment after each use and clean with warm water and food safe cleaning detergent. Failure to remove the attachment from the hub shaft may result in the attachment becoming stuck onto the hub shaft.

7. TROUBLE SHOOTING

POSSIBLE CAUSE	REMEDY
Thumb screw too tight	Loosen and hand-tighten only until snug. Don't over-tighten.
Discharge plate is blocked	Switch reverse in second.
Blade edges have dulled	Sharpen or replace.
Overloading and motor stop	Switch off and reset again.
Meat not processing properly	Knife and/or plate dull. Sharpen or replace.
	Replace washer (behind worm)
Does not turn on	Connect to power supply.
Motor turns on but worm does not	Call Skyfood Equipment LLC

6.7 Warning

Electrical or mechanical maintenance has to be undertaken by qualified personnel. The person in charge of maintenance has to be sure that the machine is under TOTAL SAFETY conditions when working.

6. GENERAL SAFETY PRACTICES

IMPORTANT

If any recommendation is not applicable to your equipment, please ignore it.

The following safety instructions are addressed to both the operator of the machine as well as the person in charge of maintenance.

The machine has to be delivered only in perfect conditions of use by the Distributor to the user. The user shall operate the machine only after being well acquainted with the safety procedures described in the present manual. **READ THIS MANUAL WITH ATTENTION.**

6.1 Basic Operation Practices

6.1.1 Dangers

Some areas of the electric device have parts that are connected or have parts connected to high voltage. These parts when touched may cause severe electrical shocks or even be lethal.

Never touch manual commands such as switches, buttons, turning keys and knobs with your hands wearing wet clothes and/or wet shoes. By not following these instructions operator could be exposed to severe electrical shocks or even to a lethal situation.

6.1.2 Warnings

- * The operator has to be well familiar with the position of ON/OFF Switch to make sure the Switch is easy to be reached when necessary.
- * Before any kind of maintenance, physically remove plug from the socket.
- * Provide space for a comfortable operation thus avoiding accidents.
- * Water or oil spilled on the floor will turn it slippery and dangerous. Make sure the floor is clean and dry.
- * Before using any commands (switch, buttons, lever), be sure it is the correct one. In case of doubt, consult this manual.
- * Never touch any manual commands (switch, buttons, lever) unadvisedly.
- * If any work is to be made by two or more persons, coordination signs will have to be given for each operation step. Every step of the operation shall be taken only if a sign has been made and responded.

6.1.3 Advices

- * In case of power shortage, immediately switch the machine off.
- * Use recommended or equivalent lubricants, oils or greases.

- * Avoid mechanical shocks, once they may cause damages or bad functioning.
- * Avoid water, dirt or dust contact to the mechanical and electrical components of the machine.
- * DO NOT change the standard characteristics of the machine.
- * DO NOT remove, tear off or maculate any safety or identification labels stuck on the machine. If any labels have been removed or are no longer legible, contact your nearest dealer for replacement.

6.2 Safety Procedures and Notes before Switching the Machine ON

IMPORTANT

Carefully read ALL INSTRUCTIONS of this manual before turning the machine ON. Be sure to well understand all the information contained in this manual. If you have any question contact your supervisor or your nearest Dealer.

6.2.1 Danger

An electric cable or electric wire with damaged jacket or bad insulation might cause electrical shocks as well as electrical leak. Before use, check the conditions of all wires and cables.

6.2.2 Advices

Be sure to well understand all the information contained in this manual. Every operation function or procedure has to be thoroughly clear.

Before using any commands (switch, buttons, lever), be sure it is the correct one. In case of doubt, consult this manual.

6.2.3 Precautions

The electric cable has to be compatible with the power required by the machine.

Cables touching the floor or close to the machine need to be protected against short circuits.

The oil reservoirs have to be filled until the indicated level. Check and refill if necessary.

6.3 Routine Inspection

6.3.1 Advice

When checking the tension of the belts or chains, DO NOT insert your fingers between the belts and the pulleys and nor between the chain and the gears.

6.3.2 Precautions

Check the motor and sliding or turning parts of the machine in case of abnormal noises. Check the tension of the belts and chains and replace the set when belts or chains show

signs of wearing.

When checking the tension of belts or chains DO NOT insert your fingers between belts and pulleys, nor between the chains and gears.

Check protections and safety devices to make sure they are working properly.

6.4 Operation

6.4.1 Warnings

Do not use the machine with long hair that could touch any part of the machine. This might lead to a serious accident. Tie your hair up well and/or cover it with a scarf.

Only trained or skilled personnel shall operate this machine.

Never touch turning parts with your hands or any other way ,

NEVER operate the machine without any original safety devices under perfect conditions.

6.5 After Finishing The Work

6.5.1 Precautions

Always TURN THE MACHINE OFF before cleaning by removing the plug from the socket.

Never clean the machine unless it has come to a complete stop.

Put all the components back to their functional positions before turning the machine ON again.

Check the level of oil.

Do NOT insert your fingers in between belts and pulleys nor chains and gears.

6.6 Maintenance

6.6.1 Danger

Any maintenance with the machine in working situation is dangerous. TURN IT OFF BY PULLING THE PLUG OFF THE SOCKET DURING MAINTENANCE.

IMPORTANT

Always remove the plug from the socket in any emergency situation.