



by **SKYSEN**

## **Instruction Manual**



**Panini Sandwich Grill**

**Model**  
**HEG-G33**

**Office**  
Phone: 1-800-503-7534 / 305-868-1603  
Fax: 305-866-2704

sales@skyfood.us - www.skyfood.us

**TOLL FREE 1-800-503-7534**



HEG-G33 is made of stainless steel. Adjustable temperature control supplies heat to both upper and bottom plate. Both features quick heating, easy operation and easy cleaning. Adjustable upper plate, it is suitable for different food thickness.

**A. Specifications:**

MODEL	HEG-G33
Voltage (V)	220
Power (kW)	5
Frequency (Hz)	60
Temperature Controlling (°F)	122-572
Unit Size (inches)	24x15x9

**B. Note:**

1. Before operation, please check “the safety notes” of this manual.
2. Make sure unit is installed on a flat surface and stable to avoid oil from flowing to one side.
3. You can adjust the upper plate by moving the regulator on the side of the bottom plate.

**C. Transportation and Storage:**

During transportation, it should be careful accommodated to prevent heavy vibration. The package cannot be kept in the open-air for long time. It should be storage in a ventilated and non-corrosive facility. If it is necessary to put it in open air for long time, a waterproof tent or cover should be provided. It cannot be put upside-down.

**D. Operation:**

1. Turn on the power and switch in the front. The red light will turn ON and the griddle will start to heat up.
2. Turn the thermostat clock wise and set the desired temperature, the green light will turn ON, the upper and bottom plates will start heating up.

3. When the plates reach the set temperature, the thermostat will cut off the power automatically, the plates stop heating and the green light is off. When the temperature is lower than the setting, the electric circuit switches on, the plates are heating again, the green light is on. This cycle keep the plates in the setting temperature range.

4. Moving the handle of upper plate, you can adjust the relative position of upper and bottom plate.

**E. Electric Diagram:**

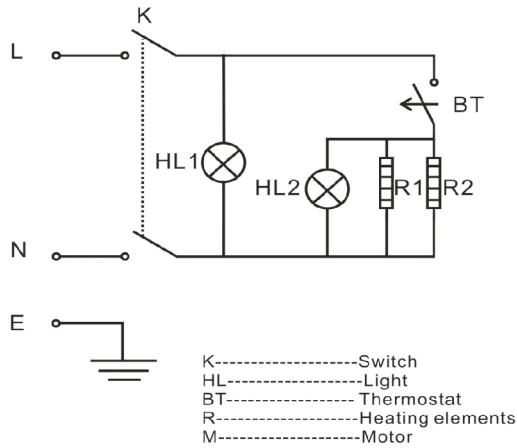

K---Switch  
 HL1---Power light  
 HL2---Heating Indication Lamp  
 BT---Thermostat  
 R1---Bottom Heating Elements  
 R2---Upper Elements

**F. Safety notes:**

1. The operation voltage should be the same as the power supply. The power voltage difference cannot be beyond 10%.
2. The griddle should be put on a flat and stable location with good air facilities.
3. You should install power switch, fuse and breaker (model: DZ12I-60G/1N, the leakage breaking current is 15mA, the normal current is 7.5mA).
4. Other objects cannot be put around the switch.
5. Before operation you should check the conversion.

**Warranty Registration**



**Questions about how to complete this form?**

Call 1-800-503-7534 / 305-868-1603

**Return completed form to:**

SKYFOOD EQUIPMENT LLC  
 11900 Biscayne Blvd. Suite 512  
 North Miami, FL 33181 - USA

**Or fax form to:**

305-866-2704

**IMPORTANT:**

Only for products of the trademark:  and 

**User Details**

\* Contact Person: \_\_\_\_\_

\* Business type:

- |  |   |
|--|---|
| <input type="checkbox"/> Bakery and Bagel Operations                   | <input type="checkbox"/> Mass Merchandiser with Grocery                   |
| <input type="checkbox"/> Bakery (Associated with Restaurant)           | <input type="checkbox"/> Mass Merchandiser with NO Grocery                |
| <input type="checkbox"/> Bowling Center                                | <input type="checkbox"/> Meat Packer and Purveyor                         |
| <input type="checkbox"/> Business and Industry In-House Feeding        | <input type="checkbox"/> Other Business that prepares or serves food      |
| <input type="checkbox"/> Butcher                                       | <input type="checkbox"/> Other Business that sells but doesn't serve food |
| <input type="checkbox"/> Catering                                      | <input type="checkbox"/> Pizza (Dine In / Carry Out)                      |
| <input type="checkbox"/> Club Stores                                   | <input type="checkbox"/> Restaurants (Independent / Chain)                |
| <input type="checkbox"/> Convenience Store                             | <input type="checkbox"/> School   |
| <input type="checkbox"/> Country Club                                  | <input type="checkbox"/> Stadiums / Coliseum                              |
| <input type="checkbox"/> Delicatessen (Chain / Restaurant)             | <input type="checkbox"/> Supermarket / Grocery                            |
| <input type="checkbox"/> Delicatessen (Independent and Non-Restaurant) | <input type="checkbox"/> Theme Park                                       |
| <input type="checkbox"/> Food Store                                    | <input type="checkbox"/> University / College                             |
| <input type="checkbox"/> Government                                    | <input type="checkbox"/> Vineyard / Winery                                |
| <input type="checkbox"/> Hospital                                      | <input type="checkbox"/> Warehouse Clubs                                  |
| <input type="checkbox"/> Lodging                                       | <input type="checkbox"/> Wholesale Baking Operation (Non-Institutional)   |

\* Company Name: \_\_\_\_\_

\* Address: \_\_\_\_\_

\* City: \_\_\_\_\_

\* State: \_\_\_\_\_ \* Zip Code: \_\_\_\_\_

\* Phone: \_\_\_\_\_ Fax: \_\_\_\_\_

\*\* E-mail: \_\_\_\_\_

Web page: \_\_\_\_\_

I would like to join the Mail List.

I would like to join the E-mail List.

**Product Details**

\* Product Commercial Item: \_\_\_\_\_

The Product Commercial Item can be found on the machine Product Identification Label.

\* Serial Number: \_\_\_\_\_ \* Confirm Serial Number: \_\_\_\_\_

This information, the Product Serial Number, can also be found on the machine Product Identification Label.

\* Proof of Purchase:  Yes  
 No

\* Purchased On: \_\_\_\_\_ / \_\_\_\_\_ / \_\_\_\_\_ (mm / dd / yyyy)

\* Purchased From: \_\_\_\_\_  
 Company Name

\* Indicates required field.

\*\* Indicates required field, not mandatory by Fax.

This product will be replaced or repaired under warranty, for a period of (1) year, beginning from the date of purchase by the original purchaser/user (“End User”), or eighteen (18) months from the date of shipment from SKYFOOD’s warehouse, whichever expires first.

Accessories will be replaced or repaired under warranty, for a period of (30) days, beginning from the date of purchase by the original purchaser/user (“End User”), or eighteen (18) months from the date of shipment from SKYFOOD’s warehouse, whichever expires first.

This warranty shall not take effect until a properly completed and executed **WARRANTY REGISTRATION** form has been received by SKYFOOD EQUIPMENT, LLC, within thirty (30) days from the date of purchase. The **WARRANTY REGISTRATION** is available either in the Instruction Manual of every Product or at SKYFOOD’s website [www.skyfood.us](http://www.skyfood.us). The End User must fill out the **WARRANTY REGISTRATION** form and send it to SKYFOOD according to the instructions posted on the referred website. **Failure to do so will VOID the warranty.**

**No extended warranties for third party products. There are no other express warranties or conditions other than the one offered by each manufacturer for products sold by SKYFOOD, not under the FLEETWOOD by SKYMPSEN and SKYMPSEN brand.**

For questions or assistance, do not return the product or accessories to the store, please call Toll Free 1-800-503-7534, or visit the Customer Service section at [www.skyfood.us](http://www.skyfood.us). For faster service please have the items name, serial number, and proof of purchase for the operator to assist you.

**SKYFOOD reserves the right to change the terms of its limited warranty at any time without any prior notice. It also reserves the right to change the design and specifications of its equipment or any related documentation at any time. The end user is not entitled to upgrades or refunds resulting from these changes.**

#### Updates

These **Terms and Conditions** were last updated on January 14<sup>th</sup>, 2014.

## General Safety Practices

### IMPORTANT

**If any item from the GENERAL SAFETY NOTIONS section is not applicable to your product, please disregard it.**

The following safety instructions are addressed to both the operator of the machine as well as the person in charge of maintenance.

The machine has to be delivered to the operator in perfect conditions of use by the Distributor to the user. The user shall operate the machine only after being well acquainted with the safety procedures described in the present manual. **READ THIS MANUAL WITH ATTENTION.**

## Basic Operation Practices

### Dangerous parts

Some parts of the electric devices are connected to high voltage points.

These parts when touched may cause severe electrical shocks or even be fatal.

Never touch commands such as buttons, switches and knobs with wet hands, wet clothes and/or shoes. By not following these instructions operator could be exposed to severe electrical shocks or even to a fatal situation.

### Warnings

The operator has to be well familiar with the position of ON/OFF Switch to make sure the Switch is easy to be reached when necessary. Before any kind of maintenance, physically remove plug from the socket.

Provide space for a comfortable operation thus avoiding accidents.

Water or oil spilled on the floor will turn it slippery and dangerous. Make sure the floor is clean and dry.

Before giving any manual command (switch, buttons, turn keys or lever) be sure the command is the correct one. Check this manual for further details if necessary.

Never use a manual command (switch, buttons, lever) unadvisedly.

If any work is to be made by two or more persons, coordination signs will have to be given for each operation step. Every step of the operation shall be taken only if the sign has been made and responded.

### Advices

In case of power shortage, immediately turn the machine OFF.

Use recommended or equivalent lubricants, oils or greases.

Avoid mechanical shocks as they may cause failures or malfunction.

Avoid penetration of water, dirt or dust into mechanical or electrical components of the machine.

DO NOT modify original characteristics of the machine.

DO NOT remove, tear off or maculate any labels stuck on the machine. If any label has been removed or is no longer legible, contact your nearest dealer for replacement.

## SAFETY PROCEDURES AND NOTES BEFORE SWITCHING ON

### IMPORTANT

Carefully read ALL INSTRUCTIONS of this manual before turning the machine ON. Be sure to be familiar with the instructions and that you have well understood all information contained in this manual. If you have any question contact your supervisor or your nearest Dealer.

#### Danger

An electric cable or electric wire with damaged jacket or bad insulation could cause electrical shocks as well as electrical leak. Before use, check conditions of all wires and cables.

#### Advices

Be sure ALL INSTRUCTIONS in this manual have been thoroughly understood.

Every function and operational procedure have to be very clear to the operator.

Contact your nearest Dealer for further questions.

Any manual command (switch, button or lever) shall be given only after being sure it is the correct one.

#### Precautions

The electric cable has to be compatible with the power required by the machine.

Cables touching the floor or close to the machine need to be protected against short circuits.

## AFTER THE WORK ENDS

#### Cares

Always clean the machine, to do the cleaning SWITCH IT OFF, AND TAKE OUT THE PLUG FROM THE ELECTRICITY SUPPLY SOCKET .

Never clean the machine BEFORE IT IS COMPLETELY STOPED.

Fit all the machine components in their due places, before switching it on again.

## MAINTENANCE

#### Dangers

Any maintenance is dangerous if made with the machine switched on.

SWITCH IT OFF AND TAKE OUT THE PLUG FROM THE SOCKET, DURING ALL THE MAINTENANCE OPERATION.

### IMPORTANT

In any emergency situation, always take the plug out of its socket.

## ADVICES

Electrical or mechanical maintenance shall be made by qualified persons.

The person in charge of the maintenance performances shall check the machine works under TOTAL SAFETY CONDITIONS.

### SKYFOOD EQUIPMENT LLC - SERVICE

For questions or assistance, call SKYFOOD EQUIPMENT Toll Free: **1-800-503-7534**, or visit the Customer Service section at [www.skyfood.us](http://www.skyfood.us).

### SKYFOOD'S LIMITED WARRANTY

Unless otherwise specified, new **FLEETWOOD by SKYSEN** and **SKYSEN** products, excluding accessories, sold by SKYFOOD EQUIPMENT, LLC. ("SKYFOOD"), for use only in the continental United States (collectively, "Products" or singularly, "Product"), are warranted to be free from defects in materials and workmanship for a period of one (1) year from the date of purchase by the original purchaser/user ("End User"), or eighteen (18) months from the date of shipment from SKYFOOD's warehouse, whichever expires first. Several new products and accessories may be warranted for a period other than one (1) year while others may be subject to travel limitations, as specified on the products Instruction Manual. **Proof of purchase must be presented; if not this warranty will be VOID.** No warranty is given or implied to a subsequent transferee or any other third party. This warranty is expressly conditional upon SKYFOOD being notified of any defects in materials or workmanship within five (5) days of its occurrence, within the warranted time period. If a notice of a claim under this warranty is timely made by the End User, SKYFOOD or a SKYFOOD's designated service company ("Service Company"), will repair or replace the Product, at SKYFOOD's discretion, subject to the additional conditions hereinafter described.

This warranty shall not apply if damage occurs from improper installation or maintenance performed by an unauthorized service company ("Service Company"), wrong voltage, nor to the extent that Products or parts have been used other than in conformance with operating and maintenance instructions, subjected to misuse or abuse or damaged by accident, acts of God, abnormal use, stress or any other matter unrelated to SKYFOOD, and beyond its reasonable control. **This warranty does NOT cover service labor and travel to perform adjustments on products and/or accessories.** In addition to wear and tear of certain items, such as, but not limited to; glass parts, blades, stones, chopper cutting knives, plates, slicing knives, cutting disc, gaskets, oil changes, sealing tape, heat seal wires, worm gears, self-lubricating bushings, carbon brushes for electric motors, and other parts expendable by nature and that need to be replaced frequently. **Electrical components are subject to natural wear and tear, and are NOT covered by this warranty. THIS WARRANTY EXCLUDES ALL ORAL, STATUTORY, EXPRESS OR IMPLIED WARRANTIES WHICH MAY BE APPLICABLE TO SKYFOOD, INCLUDING, BUT NOT LIMITED TO, ANY IMPLIED WARRANTY OF MERCHANTABILITY AND FITNESS FOR PARTICULAR PURPOSE.** Under no circumstances shall SKYFOOD be liable for loss of use, revenue or profit or for incidental or consequential damages. SKYFOOD shall under no circumstances be liable for any loss, damage, concealed damage, expense or delay of goods for any reason when said goods are in the custody, possession or control of third parties selected by SKYFOOD to forward, enter, clear, transport, or render other services with respect to such goods. The sole and exclusive remedy for breach of any warranty is limited to the remedies provided in the paragraph above.

All products held at non-commercial facilities or domiciles, must be taken or shipped, shipping charges prepaid, either to SKYFOOD's facility or a SKYFOOD's designated service company ("Service Company"). Products held at commercial facilities and weighing