



by **SKYSEN**

Instructions Manual



Vertical broiler Gyro Machine

***Model
VBGM-36***

Office

Phone: 1-800-503-7534 / 305-868-1603
Fax: 305-866-2704

Warehouse

Phone: 1-800-445-6601 / 973-482-5070
Fax: 973-482-0725

sales@skyfood.us - www.skyfood.us

TOLL FREE 1-800-503-7534

SUMMARY

1. Features	1
2. Specifications	1
3. Transportation and storage	1
4. Cautions	2
5. Operation	2
6. Cleaning and protection	3
7. Electrical Diagram	3
8. General safety practices	3

The electric vertical broiler is made up of stainless steel outer shell and speed controlled motor, specially designed with advanced technology, it is newly-designed, and easily-operated.

1- Features:

1. Temperature control: there are four groups of heating tubes divided into two sections, together with two temperature controllers.
2. Changeable distance for heating: the distances of the food can be changed according to the size of the food.

2- Specifications:

MODEL	VOLTAGE (V)	POWER (Kw)	FREQUENCY (Hz)	SIZE (inches)	NET WEIGHT (lb)	SHIPPING WEIGHT (lb)
VBGM-36	220	6	50/60	19" 11/16x25" 19/32 35" 7/16	80	99

3-Transportation and storage:

When being transported, be careful not to shake the machine violently or crash it with anything else; don't put it outdoors or in the direct sunlight. If so, avoid rainfall; Store it in ventilated places out of erosive gases; Don't put it up-side-down.

4- Cautions:

1. Put it stable on the ground level, everything should be kept 30 cm away from it. There should be space of 10cm between the back and the wall. Don't put anything that is easy to catch fire on the top of the machine, such as towel and clothes.
2. The pressure should be the same as the machine's (about 208V±10%).
3. Use a suitable switch, a fusion and a protected mode near the machine. Don't pile too much things around to make it easy to operate.
4. The ground wire of this machine (green and yellow) come out from the same wire as the power, which should be connected safely with copper screw.
5. The output connection is at the lower back part of the oven, connect copper wires of not less than 2.5mm² with ground wire safely
6. Make sure the wires contact well and firmly, the output is suitable and the ground wires are safe before using.
7. All the connection and installation should be done by qualified electricians.

5- Operation:

1. Enter the food into the main axle. Connect the power to make the power light on, which means the machine is ready to work, turn the temperature selection to the temperature you want. Then the heating light on, the electrical tube begins to work, and the temperature rises; that means food is being roasted.

2. There are parts to change the distance between an axis and electrical tube both at the top and base, when turned clockwise, it will move forwards. If you want to change the distance, the two should be vertical.

3. The main is for putting food. The food should be put in the middle of it, when it moves, the food moves too.

6- Cleaning and protection:

1. Cut off the power when cleaning to avoid accidents.

2. Use towel with non-erosive detergency to clean the outer part of the machine, the inside and around the place from which the power wire comes, every day after using. Don't use running water to wash it directly, it will do harm to the electrical function.

7- Electrical Diagram

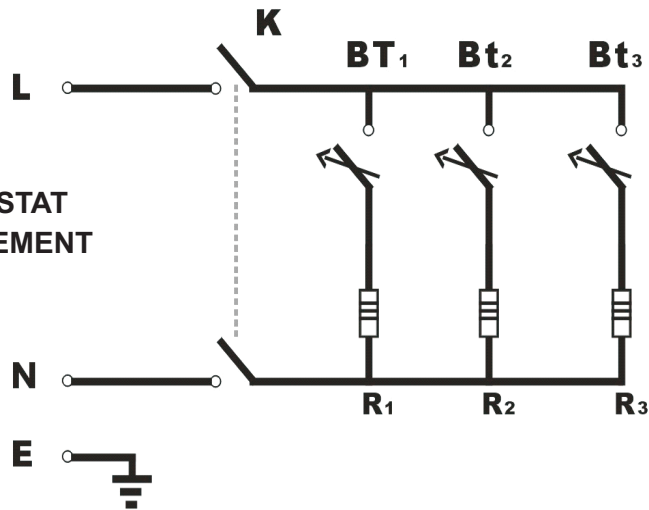

K: POWER SWITCH
BT₁/BT₂/BT₃: THERMOSTAT
R₁/R₂/R₃: HEATING ELEMENT

Warranty Registration



Questions about how to complete this form?

Call 1-800-503-7534 / 305-868-1603

Return completed form to:

SKYFOOD EQUIPMENT LLC
 11900 Biscayne Blvd. Suite 512
 North Miami, FL 33181 - USA

Or fax form to:

305-866-2704

IMPORTANT:

Only for products of the trademark: and

User Details

* Contact Person: _____

* Business type:

- | | |
|--|---|
| <input type="checkbox"/> Bakery and Bagel Operations | <input type="checkbox"/> Mass Merchandiser with Grocery |
| <input type="checkbox"/> Bakery (Associated with Restaurant) | <input type="checkbox"/> Mass Merchandiser with NO Grocery |
| <input type="checkbox"/> Bowling Center | <input type="checkbox"/> Meat Packer and Purveyor |
| <input type="checkbox"/> Business and Industry In-House Feeding | <input type="checkbox"/> Other Business that prepares or serves food |
| <input type="checkbox"/> Butcher | <input type="checkbox"/> Other Business that sells but doesn't serve food |
| <input type="checkbox"/> Catering | <input type="checkbox"/> Pizza (Dine In / Carry Out) |
| <input type="checkbox"/> Club Stores | <input type="checkbox"/> Restaurants (Independent / Chain) |
| <input type="checkbox"/> Convenience Store | <input type="checkbox"/> School |
| <input type="checkbox"/> Country Club | <input type="checkbox"/> Stadiums / Coliseum |
| <input type="checkbox"/> Delicatessen (Chain / Restaurant) | <input type="checkbox"/> Supermarket / Grocery |
| <input type="checkbox"/> Delicatessen (Independent and Non-Restaurant) | <input type="checkbox"/> Theme Park |
| <input type="checkbox"/> Food Store | <input type="checkbox"/> University / College |
| <input type="checkbox"/> Government | <input type="checkbox"/> Vineyard / Winery |
| <input type="checkbox"/> Hospital | <input type="checkbox"/> Warehouse Clubs |
| <input type="checkbox"/> Lodging | <input type="checkbox"/> Wholesale Baking Operation (Non-Institutional) |

* Company Name: _____

* Address: _____

* City: _____

* State: _____ * Zip Code: _____

* Phone: _____ Fax: _____

** E-mail: _____

Web page: _____

I would like to join the Mail List.

I would like to join the E-mail List.

Product Details

* Product Commercial Item: _____

The Product Commercial Item can be found on the machine Product Identification Label.

* Serial Number: _____ * Confirm Serial Number: _____

This information, the Product Serial Number, can also be found on the machine Product Identification Label.

* Proof of Purchase: Yes
 No

* Purchased On: _____ / _____ / _____ (mm / dd / yyyy)

* Purchased From: _____
 Company Name

* Indicates required field.

** Indicates required field, not mandatory by Fax.

This product will be replaced or repaired under warranty, for a period of (1) year, beginning from the date of purchase by the original purchaser/user (“End User”), or eighteen (18) months from the date of shipment from SKYFOOD’s warehouse, whichever expires first.

Accessories will be replaced or repaired under warranty, for a period of (30) days, beginning from the date of purchase by the original purchaser/user (“End User”), or eighteen (18) months from the date of shipment from SKYFOOD’s warehouse, whichever expires first.

This warranty shall not take effect until a properly completed and executed **WARRANTY REGISTRATION** form has been received by SKYFOOD EQUIPMENT, LLC, within thirty (30) days from the date of purchase. The **WARRANTY REGISTRATION** is available either in the Instruction Manual of every Product or at SKYFOOD’s website www.skyfood.us. The End User must fill out the **WARRANTY REGISTRATION** form and send it to SKYFOOD according to the instructions posted on the referred website. **Failure to do so will VOID the warranty.**

No extended warranties for third party products. There are no other express warranties or conditions other than the one offered by each manufacturer for products sold by SKYFOOD, not under the FLEETWOOD by SKYMSEN and SKYMSEN brand.

For questions or assistance, do not return the product or accessories to the store, please call Toll Free 1-800-503-7534, or visit the Customer Service section at www.skyfood.us. For faster service please have the items name, serial number, and proof of purchase for the operator to assist you.

SKYFOOD reserves the right to change the terms of its limited warranty at any time without any prior notice. It also reserves the right to change the design and specifications of its equipment or any related documentation at any time. The end user is not entitled to upgrades or refunds resulting from these changes.

Updates

These **Terms and Conditions** were last updated on January 14th, 2014.

8- General Safety Practices

IMPORTANT

If any item from the GENERAL SAFETY NOTIONS section is not applicable to your product, please disregard it.

The following safety instructions are addressed to both the operator of the machine as well as the person in charge of maintenance.

The machine has to be delivered to the operator in perfect conditions of use by the Distributor to the user. The user shall operate the machine only after being well acquainted with the safety procedures described in the present manual. **READ THIS MANUAL WITH ATTENTION.**

Basic Operation Practices

Dangerous parts

Some parts of the electric devices are connected to high voltage points.

These parts when touched may cause severe electrical shocks or even be fatal.

Never touch commands such as buttons, switches and knobs with wet hands, wet clothes and/or shoes. By not following these instructions operator could be exposed to severe electrical shocks or even to a fatal situation.

Warnings

The operator has to be well familiar with the position of ON/OFF Switch to make sure the Switch is easy to be reached when necessary. Before any kind of maintenance, physically remove plug from the socket.

Provide space for a comfortable operation thus avoiding accidents.

Water or oil spilled on the floor will turn it slippery and dangerous. Make sure the floor is clean and dry.

Before giving any manual command (switch, buttons, turn keys or lever) be sure the command is the correct one. Check this manual for further details if necessary.

Never use a manual command (switch, buttons, lever) unadvisedly.

If any work is to be made by two or more persons, coordination signs will have to be given for each operation step. Every step of the operation shall be taken only if the sign has been made and responded.

Advices

In case of power shortage, immediately turn the machine OFF.

Use recommended or equivalent lubricants, oils or greases.

Avoid mechanical shocks as they may cause failures or malfunction.

Avoid penetration of water, dirt or dust into mechanical or electrical components of the machine.

DO NOT modify original characteristics of the machine.

DO NOT remove, tear off or maculate any labels stuck on the machine. If any label has been removed or is no longer legible, contact your nearest dealer for replacement.

SAFETY PROCEDURES AND NOTES BEFORE SWITCHING ON

IMPORTANT

Carefully read ALL INSTRUCTIONS of this manual before turning the machine ON. Be sure to be familiar with the instructions and that you have well understood all information contained in this manual. If you have any question contact your supervisor or your nearest Dealer.

Danger

An electric cable or electric wire with damaged jacket or bad insulation could cause electrical shocks as well as electrical leak. Before use, check conditions of all wires and cables.

Advices

Be sure ALL INSTRUCTIONS in this manual have been thoroughly understood.

Every function and operational procedure have to be very clear to the operator.

Contact your nearest Dealer for further questions.

Any manual command (switch, button or lever) shall be given only after being sure it is the correct one.

Precautions

The electric cable has to be compatible with the power required by the machine.

Cables touching the floor or close to the machine need to be protected against short circuits.

AFTER THE WORK ENDS

Cares

Always clean the machine, to do the cleaning SWITCH IT OFF, AND TAKE OUT THE PLUG FROM THE ELECTRICITY SUPPLY SOCKET .

Never clean the machine BEFORE IT IS COMPLETELY STOPPED.

Fit all the machine components in their due places, before switching it on again.

MAINTENANCE

Dangers

Any maintenance is dangerous if made with the machine switched on.

SWITCH IT OFF AND TAKE OUT THE PLUG FROM THE SOCKET, DURING ALL THE MAINTENANCE OPERATION.

IMPORTANT

In any emergency situation, always take the plug out of its socket.

ADVICES

Electrical or mechanical maintenance shall be made by qualified persons.

The person in charge of the maintenance performances shall check the machine works under TOTAL SAFETY CONDITIONS.

SKYFOOD EQUIPMENT LLC - SERVICE

For questions or assistance, call SKYFOOD EQUIPMENT Toll Free: 1-800-503-7534, or visit the Customer Service section at www.skyfood.us.

SKYFOOD'S LIMITED WARRANTY

Unless otherwise specified, new **FLEETWOOD by SKYMSSEN** and **SKYMSSEN** products, excluding accessories, sold by SKYFOOD EQUIPMENT, LLC. ("SKYFOOD"), for use only in the continental United States (collectively, "Products" or singularly, "Product"), are warranted to be free from defects in materials and workmanship for a period of one (1) year from the date of purchase by the original purchaser/user ("End User"), or eighteen (18) months from the date of shipment from SKYFOOD's warehouse, whichever expires first. Several new products and accessories may be warranted for a period other than one (1) year while others may be subject to travel limitations, as specified on the products Instruction Manual. **Proof of purchase must be presented; if not this warranty will be VOID.** No warranty is given or implied to a subsequent transferee or any other third party. This warranty is expressly conditional upon SKYFOOD being notified of any defects in materials or workmanship within five (5) days of its occurrence, within the warranted time period. If a notice of a claim under this warranty is timely made by the End User, SKYFOOD or a SKYFOOD's designated service company ("Service Company"), will repair or replace the Product, at SKYFOOD's discretion, subject to the additional conditions hereinafter described.

This warranty shall not apply if damage occurs from improper installation or maintenance performed by an unauthorized service company ("Service Company"), wrong voltage, nor to the extent that Products or parts have been used other than in conformance with operating and maintenance instructions, subjected to misuse or abuse or damaged by accident, acts of God, abnormal use, stress or any other matter unrelated to SKYFOOD, and beyond its reasonable control. **This warranty does NOT cover service labor and travel to perform adjustments on products and/or accessories.** In addition to wear and tear of certain items, such as, but not limited to; glass parts, blades, stones, chopper cutting knives, plates, slicing knives, cutting disc, gaskets, oil changes, sealing tape, heat seal wires, worm gears, self-lubricating bushings, carbon brushes for electric motors, and other parts expendable by nature and that need to be replaced frequently. **Electrical components are subject to natural wear and tear, and are NOT covered by this warranty. THIS WARRANTY EXCLUDES ALL ORAL, STATUTORY, EXPRESS OR IMPLIED WARRANTIES WHICH MAY BE APPLICABLE TO SKYFOOD, INCLUDING, BUT NOT LIMITED TO, ANY IMPLIED WARRANTY OF MERCHANTABILITY AND FITNESS FOR PARTICULAR PURPOSE.** Under no circumstances shall SKYFOOD be liable for loss of use, revenue or profit or for incidental or consequential damages. SKYFOOD shall under no circumstances be liable for any loss, damage, concealed damage, expense or delay of goods for any reason when said goods are in the custody, possession or control of third parties selected by SKYFOOD to forward, enter, clear, transport, or render other services with respect to such goods. The sole and exclusive remedy for breach of any warranty is limited to the remedies provided in the paragraph above.

All products held at non-commercial facilities or domiciles, must be taken or shipped, shipping charges prepaid, either to SKYFOOD's facility or a SKYFOOD's designated service company ("Service Company"). Products held at commercial facilities and weighing