



by **SKYSEN**

Instructions Manual / Manual de Instrucciones



Industrial Blender / Licuador Industrial

Model / Modelos

LAR-10MB

Office

Phone: 1-800-503-7534 / 305-868-1603
Fax: 305-866-2704

Warehouse

Phone: 1-800-445-6601 / 973-482-5070
Fax: 973-482-0725

sales@skyfood.us - www.skyfood.us

TOLL FREE 1-800-503-7534

SUMMARY / INDICE

1. ENGLISH _____ 01

2. ESPAÑOL _____ 10



LAR - 10MB

SUMMARY

1. Introduction	02
1.1 Safety	02
1.2 Main Components	02
1.3 Technical Characteristics	03
2. Installation and Pre Operation	03
2.1 Installation	03
2.2 Pre Operation	03
3. Operation	04
3.1 Starting	04
3.2 Feeding Procedures	04
3.3 Cleaning	05
4. General Safety Practices	06
4.1 Basic Operation Procedures	06
4.2 Safety Procedures and Notes Before Switching the Machine On	07
4.3 Routine Inspection	07
4.4 Operation	08
4.5 After Finishing the Work	08
4.6 Maintenance	08
4.7 Advices	08
5. Analysis and Problem Solving	08
5.1 Problems, Causes e Solutions	08
5.2 Electric Diagram	09

Warranty Registration



Questions about how to complete this form?

Call 1-800-503-7534 / 305-868-1603

Return completed form to:

SKYFOOD EQUIPMENT LLC
11900 Biscayne Blvd. Suite 512
North Miami, FL 33181 - USA

Or fax form to:

305-866-2704

IMPORTANT:

Only for products of the trademark: and

User Details

* Contact Person: _____

* Business type:

- | | |
|--|---|
| <input type="checkbox"/> Bakery and Bagel Operations | <input type="checkbox"/> Mass Merchandiser with Grocery |
| <input type="checkbox"/> Bakery (Associated with Restaurant) | <input type="checkbox"/> Mass Merchandiser with NO Grocery |
| <input type="checkbox"/> Bowling Center | <input type="checkbox"/> Meat Packer and Purveyor |
| <input type="checkbox"/> Business and Industry In-House Feeding | <input type="checkbox"/> Other Business that prepares or serves food |
| <input type="checkbox"/> Butcher | <input type="checkbox"/> Other Business that sells but doesn't serve food |
| <input type="checkbox"/> Catering | <input type="checkbox"/> Pizza (Dine In / Carry Out) |
| <input type="checkbox"/> Club Stores | <input type="checkbox"/> Restaurants (Independent / Chain) |
| <input type="checkbox"/> Convenience Store | <input type="checkbox"/> School |
| <input type="checkbox"/> Country Club | <input type="checkbox"/> Stadiums / Coliseum |
| <input type="checkbox"/> Delicatessen (Chain / Restaurant) | <input type="checkbox"/> Supermarket / Grocery |
| <input type="checkbox"/> Delicatessen (Independent and Non-Restaurant) | <input type="checkbox"/> Theme Park |
| <input type="checkbox"/> Food Store | <input type="checkbox"/> University / College |
| <input type="checkbox"/> Government | <input type="checkbox"/> Vineyard / Winery |
| <input type="checkbox"/> Hospital | <input type="checkbox"/> Warehouse Clubs |
| <input type="checkbox"/> Lodging | <input type="checkbox"/> Wholesale Baking Operation (Non-Institutional) |

* Company Name: _____

* Address: _____

* City: _____

* State: _____ * Zip Code: _____

* Phone: _____ Fax: _____

** E-mail: _____

Web page: _____

I would like to join the Mail List.

I would like to join the E-mail List.

Product Details

* Product Commercial Item: _____

The Product Commercial Item can be found on the machine Product Identification Label.

* Serial Number: _____ * Confirm Serial Number: _____

This information, the Product Serial Number, can also be found on the machine Product Identification Label.

* Proof of Purchase: Yes
 No

* Purchased On: _____ / _____ / _____ (mm / dd / yyyy)

* Purchased From: _____
Company Name

* Indicates required field.

** Indicates required field, not mandatory by Fax.

service company ("Service Company"). Products held at commercial facilities and weighing less than seventy (70) lbs. must be taken or shipped, shipping charges are prepaid, either to SKYFOOD's facility or to a Service Company. Mileage or travel time will NOT be paid. SKYFOOD offers a limited on-site warranty for products ONLY held at commercial facilities, whose net weight exceeds seventy (70) lbs., provided they are installed in a location that is within a thirty (30) mile radius of a Service Company. **End Users are responsible for all extra travel and mileage rates.** In this case, warranty services will be provided during regular business hours.

This product will be replaced or repaired under warranty, for a period of (1) year, beginning from the date of purchase by the original purchaser/user ("End User").

Accessories will be replaced or repaired under warranty, for a period of (30) days, beginning from the date of purchase by the original purchaser/user ("End User").

This warranty shall not take effect until a properly completed and executed **WARRANTY REGISTRATION** form has been received by SKYFOOD EQUIPMENT, LLC, within thirty (30) days from the date of purchase. The **WARRANTY REGISTRATION** is available either in the Instruction Manual of every Product or at SKYFOOD's website www.skyfood.us. The End User must fill out the **WARRANTY REGISTRATION** form and send it to SKYFOOD according to the instructions posted on the referred website. **Failure to do so will VOID the warranty.**

For questions or assistance, do not return the product or accessories to the store, please call Toll Free 1-800-503-7534 for Customer Support, or visit the Customer Service section of www.skyfood.us. For faster service please have the items name, serial number, and proof of purchase for the operator to assist you.

SKYFOOD reserves the right to change the terms of its limited warranty at any time without any prior notice. It also reserves the right to change the design and specifications of its equipment or any related documentation at any time. The end user is not entitled to upgrades or refunds resulting from these changes.

Updates

These **Terms and Conditions** were last updated on August 22th, 2011.

1. Introduction

1.1 Safety

The High Performance Industrial Blenders are machines simple to use and to clean. However for your safety read the following instructions in order to avoid accidents:

- 1.1.1 Always unplug the machine when cleaning, servicing or when any other operation is needed.
- 1.1.2 Never use tools that do not belong to the machine during operation.
- 1.1.3 Before using the machine check if Cup N°02 (Pic.01) is properly fitted in its position.
- 1.1.4 Never throw water directly to the machine.
- 1.1.5 Do not operate the machine wearing wet clothes or wet shoes.
- 1.1.6 Before operating the machine be sure it is grounded properly.

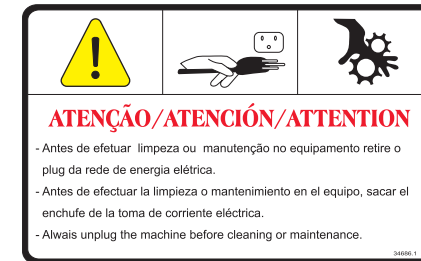

1.2 Main Components

All components are made with carefully selected materials, in accordance with Siemens experience and standard testing procedures.

Picture - 01

- 01- Lid
- 02- Cup
- 03- Cup Flange
- 04- Motor Support Flange
- 05- Motor Housing
- 06- Base
- 07-Voltage selector Switch 100/220V
- 08- ON/OFF Switch



02

1.3 Technical Characteristics

Table - 01

Technical Data	Units	LAR-10MB
Voltage	[V]	127 / 220
Frequency	[Hz]	50 ou 60(*)
Power Rating	[CV]	0,5
Consumption	[kW/h]	0,38
Height	[Inches]	29 7/8"
Width	[Inches]	12 7/8"
Depth	[Inches]	12 5/8"
Net Weigth	[lb]	22
Shipping Weigth	[lb]	36
Rotation	[rpm]	3500

(*) Frequency and voltage will be only the ones indicated on motor characteristics label.

2. Installation and Pre Operation

2.1 Installation

The Blender is to be installed onto a leveled surface approximately 850mm high.

The High Performance Industrial Blenders were developed to be used in both voltages: 110 or 220V . Upon receiving the Blender adjust its voltage according to the power supply source using the voltage selector switch N° 07(pic.01) located at the bottom of the machine. Adjust it if necessary.

The cord has a plug with two pins and a grounding wire . It is mandatory the three of them to be connected before to start to use the blender .

2.2 Pre Operation

IMPORTANT

When installing the Cup N°02 (Pic.01) on the machine be sure it is perfectly fitted. The Cup can be fitted on the machine in any position; which guarantees a perfect operation.

First of all check if the Blender is firm in its position. It is recommended to work with the machine on a flat surface with approximately 850 mm of height.

SKYFOOD EQUIPMENT LLC - SERVICE

For questions or assistance with products **FLEETWOOD** by **SKYMSSEN** and **SKYMSSEN**, call SKYFOOD EQUIPMENT Toll Free : **1-800-503-7534**, 24h Customer support, or visit the Customer Service section of www.skyfood.us.

SKYFOOD'S LIMITED WARRANTY

Unless otherwise specified, new **FLEETWOOD** by **SKYMSSEN** and **SKYMSSEN** products, excluding accessories, sold by SKYFOOD EQUIPMENT, LLC. ("SKYFOOD"), for use only in the continental United States (collectively, "Products" or singularly, "Product"), are warranted to be free from defects in materials and workmanship for a period of one (1) year from the date of purchase by the original purchaser/user ("End User"). Several new products and accessories may be warranted for a period other than one (1) year while others may be subject to travel limitations, as specified on the products Instruction Manual. **Proof of purchase must be presented; if not this warranty will be VOID.** No warranty is given or implied to a subsequent transferee or any other third party. This warranty is expressly conditional upon SKYFOOD being notified of any defects in materials or workmanship within five (5) days of its occurrence, within the warranted time period. If a notice of a claim under this warranty is timely made by the End User, SKYFOOD or a SKYFOOD's designated service company ("Service Company"), will repair or replace the Product, at SKYFOOD's discretion, subject to the additional conditions hereinafter described.

This warranty shall not apply if damage occurs from improper installation or maintenance performed by an unauthorized service company ("Service Company"), wrong voltage, nor to the extent that Products or parts have been used other than in conformance with operating and maintenance instructions, subjected to misuse or abuse or damaged by accident, acts of God, abnormal use, stress or any other matter unrelated to SKYFOOD, and beyond its reasonable control. **This warranty does NOT cover service labor and travel to perform adjustments on products and/or accessories.** In addition to wear and tear of certain items, such as, but not limited to; glass parts, blades, stones, chopper cutting knives, plates, slicing knives, cutting disc, gaskets, oil changes, sealing tape, heat seal wires, worm gears, self-lubricating bushings, carbon brushes for electric motors, and other parts expendable by nature and that need to be replaced frequently. **Electrical components are subject to natural wear and tear, and are NOT covered by this warranty. THIS WARRANTY EXCLUDES ALL ORAL, STATUTORY, EXPRESS OR IMPLIED WARRANTIES WHICH MAY BE APPLICABLE TO SKYFOOD, INCLUDING, BUT NOT LIMITED TO, ANY IMPLIED WARRANTY OF MERCHANTABILITY AND FITNESS FOR PARTICULAR PURPOSE.** Under no circumstances shall SKYFOOD be liable for loss of use, revenue or profit or for incidental or consequential damages. SKYFOOD shall under no circumstances be liable for any loss, damage, concealed damage, expense or delay of goods for any reason when said goods are in the custody, possession or control of third parties selected by SKYFOOD to forward, enter, clear, transport, or render other services with respect to such goods. The sole and exclusive remedy for breach of any warranty is limited to the remedies provided in the paragraph above.

All products held at non-commercial facilities or domiciles, must be taken or shipped, shipping charges prepaid, either to SKYFOOD's facility or a SKYFOOD's designated

Tabla - 02

Problemas	Causas	Soluções
* La Máquina no se prende.	* Falta de Energia eléctrica, o enchufe desconectado de la red eléctrica. * Problema en el circuito eléctrico interno o externo de la máquina.	* Verifique si el enchufe está conectado la toma de corriente y si hay energía eléctrica en la red eléctrica. * Llame el servicio técnico.
* Vaso presenta filtracion.	* Problema en el sistema de vedamiento.	* Llame el servicio técnico.
*La maquina se prende pero el motor gira despacio.	* Capacitor de arranque defectuoso.	* Llame el servicio técnico.

5.2 Diagrama Eléctrico

Llave Prender/Desligar

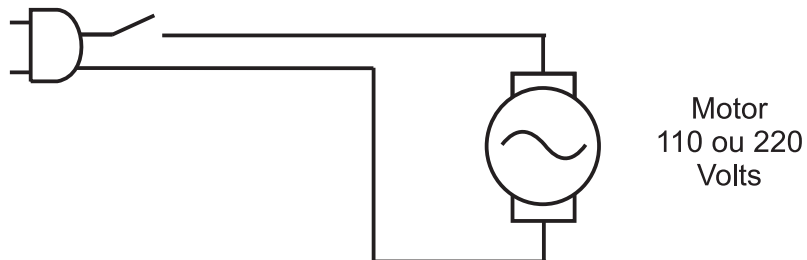

Before using the machine all parts that get in contact with food must be washed with running water and neutral soap. To clean your Blender read item 3.3 Cleaning on this Manual (pag.4).

3. Operation

3.1 Starting

IMPORTANT
Before removing or installing the Cup N°02 (Pic.01) be sure the motor has completely stopped in order to avoid coupling premature wear out.

The Blender is activated by turning the On/Off Switch N°08 (Pic.01) located at the Motor Housing N°05 (Pic.01) to ON position.

3.2 Feeding Procedure

The High Performance Industrial Blender works at high speed (approximately 3.500 rpm 60Hz) . To feed it proceed as follows:

- 1 - Remove the Lid N°01 (Pic.01).
- 2 - Put product inside the Cup N°02 (Pic.01) with the machine switched OFF.
- 3- Place the Lid N°01 (Pic.01) and switch the machine ON.

IMPORTANT
The processing time depends on the kind of product. It is not recommended to blend products without the addition of any liquid, otherwise it will overheat and damage the Cup seal.

IMPORTANT
NEVER SWITCH THE MACHINE ON WITHOUT LOAD IN IT BECAUSE IT WILL CAUSE IRREPARABLE DAMAGES.

3.3 Cleaning

IMPORTANT

Never do cleaning with the machine plugged in. Always unplug the machine before cleaning. Before removing the Cup be sure the motor has completely stopped. When washing inside the cup be careful with the knife.

The new SKYMSEN Blenders models were developed for easy cleaning. Wash the removable parts with running water and neutral soap and wipe up the others with a damp cloth.

Follow the below instructions to wash the removable parts:

- 3.3.1 Unplug the machine.
- 3.3.2 Remove the Lid N°01 (Pic.02) first then the Cup N°02 (Pic.02).
- 3.3.3 Wash all removable parts with running water and neutral soap.
- 3.3.4 To reinstall them, follow the above order inversely.
- 3.3.5 To clean the Motor Housing N°03 (Pic.02) use a wet cloth with alcohol.

IMPORTANT

When washing inside the Cup be careful with the knife as it has sharp edges.

Al verificar la tensión de las correas, **NO** coloque los dedos entre las correas y las poleas.

4.6 Manutención

4.6.1 Peligros

Con la maquina prendida cualquier operación de manutención es peligrosa. **DESCONÉCTELA FÍSICAMENTE DE LA RED ELÉCTRICA, DURANTE TODA LA OPERACIÓN DE MANUTENCIÓN.**

IMPORTANTE

Siempre retire la enchufe del soquete en cualquier caso de emergencia.

4.7 Avisos

La manutención eléctrica o mecánica debe ser hecha por una persona calificada para hacer el trabajo.

La persona encargada por la manutención debe certificarse que la maquina trabaje bajo condiciones **TOTALES DE SEGURIDAD.**

5 PROBLEMAS, CAUSAS Y SOLUCIONES

5.1 Problemas, Causas y Soluciones

Las Licuadoras Industriales de Alto Rendimiento fueron diseñadas para que necesiten un mínimo de manutención. Sin embargo pueden ocurrir algunas irregularidades en su funcionamiento, debido al desgaste natural causado por su uso.

Caso haya algún problema con su maquina, verifique la Tabla – 02 abajo, donde están indicadas algunas soluciones recomendadas.

El accionamiento de un comando manual (botón, llave eléctrica, palanca, etc.) debe ser hecho siempre después que se tenga la certitud de que es el comando correcto.

4.2.3 Cuidados

El cable de alimentación de energía eléctrica de la maquina, debe tener una sección suficiente para soportar la potencia eléctrica consumida. Cables eléctricos que estuvieren en el suelo cerca de la maquina, deben ser protegidos para evitar corto circuitos.

4.3 Inspección de Rutina

4.3.1 Aviso

Al averiguar la tensión de las correas, **NO** coloque los dedos entre las correas y las poleas.

4.3.2 Cuidados

Verifique los motores y las partes deslizantes o girantes de la maquina, con relación a ruidos anormales.

Verifique la tensión de las correas, y sustituya el conjunto, caso alguna correa o polea tenga desgaste. Al verificar la tensión de las correas, **NO** coloque los dedos entre las correas y poleas.

Verifique las protecciones y los dispositivos de seguridad para que siempre funcionen adecuadamente.

4.4 Operación

4.4.1 Avisos

No trabaje con pelo largo, que pueda tocar cualquier parte de la maquina, pues el mismo podría causar serios accidentes. Amárrelo para arriba y para atrás, o cúbralo con un pañuelo.

Solamente operadores entrenados y calificados pueden operar la maquina. Nunca toque con las manos o de cualquier otra manera, partes girantes de la maquina.

JAMÁS opere la maquina, sin algún de sus accesorios de seguridad.

4.5 Después de Terminar el Trabajo

4.5.1 Cuidados

Siempre limpie la maquina. Para tanto, deslíguela físicamente del soquete. Nunca limpie la maquina antes de su **PARADA COMPLETA**.

Recoloque todos los componentes de la maquina en sus lugares, antes de ligarla otra vez.

4. General Safety Practices

IMPORTANT

If any item from the **GENERAL SAFETY NOTIONS** section is not applicable to your product, please disregard it.

The following safety instructions are addressed to both the operator of the machine as well as the person in charge of maintenance. The machine has to be delivered to the operator in perfect conditions of use by the Distributor to the user. The user shall operate the machine only after being well acquainted with the safety procedures described in the present manual. **READ THIS MANUAL WITH ATTENTION.**

4.1 Basic Operation Practices

4.1.1 Dangerous parts

Some parts of the electric devices are connected to high voltage points. These parts when touched may cause severe electrical shocks or even be FATAL.

Never touch commands such as buttons, switches and knobs with wet hands, wet clothes and/or shoes. By not following these instructions operator could be exposed to severe electrical shocks or even to a FATAL situation.

4.1.2 Warnings

The operator has to be well familiar with the position of ON/OFF Switch to make sure the Switch is easy to be reached when necessary. Before any kind of maintenance, physically remove plug from the socket.

Provide space for a comfortable operation thus avoiding accidents.

Water or oil spilled on the floor will turn it slippery and dangerous. Make sure the floor is clean and dry.

Before giving any manual command (switch, buttons, turn keys or lever) be sure the command is the correct one. Check this manual for further details if necessary.

Never use a manual command (switch, buttons, lever) unadvisedly.

If any work is to be made by two or more persons, coordination signs will have to be given for each operation step. Every step of the operation shall be taken only if the sign has been made and responded.

4.1.3 Advices

In case of power shortage, immediately turn the machine OFF.

Use recommended or equivalent lubricants, oils or greases.

Avoid mechanical shocks as they may cause failures or malfunction.

Avoid penetration of water, dirt or dust into mechanical or electrical components of the machine.

DO NOT MODIFY original characteristics of the machine.

DO NOT REMOVE, TEAR OFF or MACULATE ANY SAFETY or IDENTIFICATION LABELS stuck on the machine. If any label has been removed or is no longer legible, contact your nearest dealer for replacement.

4.2 Safety Procedures and Notes Before Switching Machine ON

IMPORTANT

Carefully read ALL INSTRUCTIONS of this manual before turning the machine ON. Be sure to be familiar with the instructions and that you have well understood all information contained in this manual. If you have any question contact your supervisor or your nearest Dealer.

4.2.1 Danger

An electric cable or electric wire with damaged jacket or bad insulation could cause electrical shocks as well as electrical leak. Before use, check conditions of all wires and cables.

4.2.2 Advices

Be sure ALL INSTRUCTIONS in this manual have been thoroughly understood. Every function and operational procedure have to be very clear to the operator. Contact your nearest Dealer for further questions.

Any manual command (switch, button or lever) shall be given only after being sure it is the correct one.

4.2.3 Precautions

The electric cable has to be compatible with the power required by the machine. Cables touching the floor or close to the machine need to be protected against short circuits.

4.3 Routine Inspection

4.3.1 Advice

When checking the tension of the belts or chains, DO NOT introduce your fingers between the belts and the pulleys and nor between the chain and the gears.

4.3.2 Precautions

Check if motors and sliding or turning parts of the machine produce abnormal noises.

Check the tension of the belts and chains and replace the set when belt or chain show signs of being worn out.

When checking tensions of belts or chain DO NOT introduce your fingers between belts and pulleys, nor between the chains and gears.

Check protections and safety devices to make sure they are working properly.

Antes de accionar cualquier comando manual (botones, llaves eléctricas, palancas, etc.) verifique siempre si el comando es el correcto, o en caso de dudas, consulte este Manual.

Nunca toque ni accione un comando manual (botones, llaves eléctricas, palancas, etc.) por acaso.

Si un trabajo debe ser hecho por dos o más personas, señales de coordinación deben ser dados antes de cada operación. La operación siguiente no debe ser comenzada sin que la respectiva señal sea dada y respondida.

4.1.3 Avisos

En el caso de falta de energía eléctrica, desligue inmediatamente la llave liga/desliga.

Use solamente aceites lubricantes o grasas recomendadas o equivalentes.

Evite choques mecánicos, ellos pueden causar fallas o malo funcionamiento.

Evite que agua, suciedad o polvo entren en los componentes mecánicos y eléctricos de la maquina.

NO ALTERE las características originales de la maquina.

NO SUCIE, RASGUE O RETIRE CUALQUIER ETIQUETA DE SEGURIDAD O DE IDENTIFICACIÓN. Caso alguna esté ilegible o perdida, solicite otra al Asistente Técnico más cercano.

LEA ATENTAMENTE Y CON CUIDADO LAS ETIQUETAS DE SEGURIDAD Y DE IDENTIFICACIÓN CONTENIDAS EN LA MAQUINA, ASÍ COMO LAS INSTRUCCIONES Y LAS TABLAS TÉCNICAS CONTENIDAS EN ESTE MANUAL.

4.2 Cuidados y Observaciones Antes de Ligar la Maquina.

IMPORTANTE

Lea con atención y cuidado las INSTRUCCIONES contenidas en este Manual, antes de ligar la maquina. Certifíquese que entendió correctamente todas las informaciones. En caso de duda, consulte su superior o el Revendedor.

4.2.1 Peligro

Cables o hilos eléctricos con aislamiento dañado, pueden provocar choques eléctricos. Antes de usarlos verifique sus condiciones.

4.2.2 Avisos

Esté seguro que las INSTRUCCIONES contenidas en este Manual, estén completamente entendidas. Cada función o procedimiento de operación y de manutención debe estar perfectamente entendido.

Siga el siguiente procedimiento para la remoción de las partes removibles:

Desconecte la maquina de la red eléctrica.
Retire la Tapa N° 01 y el Vaso N° 02 (Fig.01).
Lave las partes removibles con agua y jabón.
Para remontar, proceda de manera inversa a la descrita arriba.

IMPORTANTE

Al lavar el Vaso tome cuidado con la cuchilla, pues la misma posee hilos cortantes.

4 NOCIONES GENERALES DE SEGURIDAD

IMPORTANTE

En el caso de algun item de las NOCIONES GENERALES DE SEGURIDAD no ser aplicable en su producto, por favor desconsiderar el mismo.

Las Nociones Generales de Seguridad fueran preparadas para orientar y instruir adecuadamente a los operadores de las maquinas, así como aquellos que serán responsables por su manutención.

La maquina solamente debe ser entregue al operador en buenas condiciones de uso, al que el operador debe ser orientado cuanto al uso y a la seguridad de la maquina por el Revendedor. El operador solamente debe usar la maquina con el conocimiento completo de los cuidados que deben ser tomados, después de LEER ATENTAMENTE TODO ESTE MANUAL.

4.1 Practicas Básicas de Operación

4.1.1 Peligros

Algunas partes del accionamiento eléctrico presentan pontos o terminales con altos voltajes. Cuando tocados pueden ocasionar graves choques eléctricos, o hasta la muerte de una persona.

Nunca toque un comando manual (botón, llave eléctrica, etc.) con las manos, zapatos o ropas mojadas. No obedecer a esta recomendación, también podrá provocar choques eléctricos, o hasta la muerte de una persona.

4.1.2 Advertencias

El local de la llave liga/desliga debe ser bien conocido, para que sea posible accionarla a cualquier momento sin la necesidad de procurarla.

Antes de cualquier manutención desconecte la maquina de la red eléctrica.

Proporcione espacio suficiente para evitar caídas peligrosas.

Agua o aceite podrán hacer resbaloso y peligroso el piso. Para evitar accidentes el piso debe estar seco y limpio.

4.4 Operation

4.4.1 Advice

Be sure your hair is not loose in order to avoid getting caught by turning parts which could lead to a serious accident. Tie your hair well up and/or cover your head with a scarf.

The operation performed by not trained or skilled personnel shall be forbidden.

Never touch turning parts with your hands or in any other way.

NEVER operate machine without all original safety devices under perfect conditions.

4.5 After Finishing The Work

4.5.1 Precautions

Always TURN THE MACHINE OFF by removing the plug from the socket before cleaning the machine.

Never clean the machine unless it has come to a COMPLETE STOP.

Put all components back to their functional positions before turning it ON again. DO NOT place your fingers in between belts and pulleys nor chains and gears.

4.6 Maintenance

4.6.1 Danger

Any maintenance with the machine in working situation is dangerous. TURN IT OFF BY PULLING THE PLUG OFF THE SOCKET DURING MAINTENANCE.

IMPORTANT

Always unplug the machine when emergency cases arise.

4.7 Advice

Electrical or mechanical maintenance must be done by qualified personal for such operation.

Person in charge has to be sure that the machine is under TOTAL SAFETY conditions when working.

5 Analysis and Problems Solving

5.1 Problem, causes and solutions

The High Performance Industrial Blenders were designed to operate with the need of minimum maintenance but the natural wearing caused by longer use of the equipment may occasionally cause some malfunctions.

If such problem occurs with your Blender refer to Table 02 in which the most common situations are listed with recommended solutions.

Table - 02

Problems	Causes	Solutions
* The machine does not switch On.	* Lack of power. * Problem in the internal or external electric circuit of the machine.	* Check if machine is plugged in and if there is power in the power supply source. * Call technical assistance.
* Cup is leaking.	* Damaged seal.	* Call technical assistance.
* The machine switches on but the motor turns slowly.	* Defective motor capacitor.	* Call technical assistance.
* Power cord damaged.	* Damage during transportartion.	* Call technical assistance.

5.2 Electrical Diagram

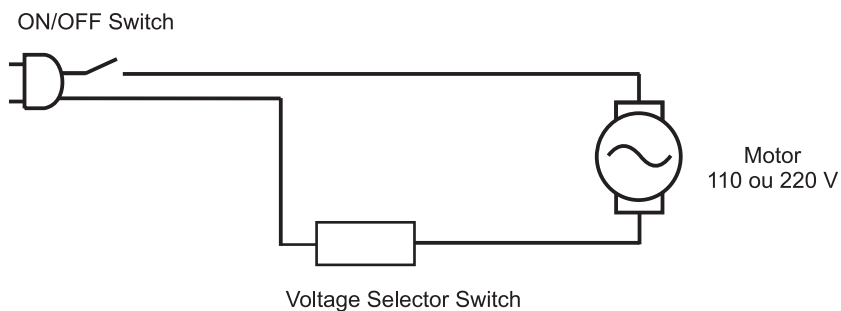

El accionamiento de la maquina es hecho a través de la Llave Liga/Desliga N° 08 (Fig.01) ubicada en su Gabinete N° 05 (Fig.01).

3.2 Procedimiento para Utilización

Las Licuadoras Industriales de Alto Rendimiento son maquinas que trabajan en alta velocidad (aproximadamente 3.500 rpm). Para alimentarlas proceda de la siguiente manera:

1. Retira la Tapa N° 01 (Fig.01).
2. Coloque el producto en el Vaso N° 02 (Fig.01) con la maquina apagada.
3. Coloque la Tapa N° 01 (Fig.01) en el Vaso N° 02 (Fig.01) y prenda la maquina.

IMPORTANTE

El tiempo de procesamiento depende de cada producto. No es recomendable la trituración de productos sólidos sin el auxilio de liquido, pues podrá ocurrir sobrecalentamiento y consecuentemente dañar el sistema de vedamiento del Vaso.

IMPORTANTE

NUNCA PRENDA LA MAQUINA SIN PRODUCTO, PUES DAÑOS IRREPARABLES IRÁN OCURRIR.

3.3 Limpieza

IMPORTANTE

Nunca haga limpieza con la maquina conectada a la red eléctrica. Para tanto desconéctela de la toma de energía. Antes de retirar el Vaso, esté seguro de la completa parada del Motor. Al lavar el interior del Vaso tome cuidado con la cuchilla.

Los modelos de Licuadoras SKYMSEN fueron proyectados para facilitar la limpieza de la maquina. Para hacer la limpieza, lave las partes removibles con agua y jabón neutro y en las demás pase solamente un paño húmedo.

Antes de encender el equipo verifique si el voltaje de la maquina es el mismo que lo de la red eléctrica, 110 o 220V. Si necesario ajústelo utilizando la Llave Selectora de Voltaje N° 07 (Fig.01) ubicada en la parte inferior de la maquina.

El cable de alimentación posee una enchufe con dos pernos rectangulares y un redondo. Es obligatorio que los tres puntos estén debidamente conectados antes de accionar el equipo.

2.2 Pre Operación

Foto - 02



IMPORTANTE

Certifíquese que el Vaso N° 02 (Fig.01) esté bien encajado. El sistema de encaje fija el Vaso en cualquier posición garantizando su perfecto funcionamiento.

Inicialmente verifique si la Licuadora está firme en su posición. Es recomendable trabajar con la maquina sobre una superficie plana con altura de aproximadamente 850mm.

Antes de usarla, debe lavarse las partes que entran en contacto con el producto a ser procesado, con agua y jabón. Para hacer la limpieza de su Licuadora, lee el ítem 3.3 Limpieza .

3 OPERACIÓN

3.1 Accionamiento

IMPORTANTE

Cuando desear retirar o colocar el Vaso N° 02 (Fig.01) esté seguro de la completa parada del Motor, evitándose así el desgaste prematuro de los acoples.

ÍNDICE

1. Introducción	11
1.1 Seguridad	11
1.2 Componentes Principales	12
1.3 Características Técnicas	12
2. Instalación y Pre Operacion	12
2.1 Instalación	12
2.2 Pre Operacion	03
3. Operación	13
3.1 Accionamiento	13
3.2 Procedimientos para Utilizacion	14
3.3 Limpieza	14
4. Nociones Generales de Seguridad	15
4.1 Practicas Basicas de Operación	15
4.2 Cuidados y Observaciones Antes de Prender la Maquina	16
4.3 Inspección de Rutina	17
4.4 Operación	17
4.5 Después de Terminar el Trabajo	17
4.6 Mantenimiento	18
4.7 Avisos	18
5. Análisis y Resoluciones de Problemas	18
5.1 Problemas, Causas y Soluciones	18
5.2 Diagrama Eléctrico	19

1. INTRODUCCIÓN

1.1 Seguridad

Las Licuadoras Industriales de Alto Rendimiento, son maquinas simples de se operar y de fácil limpieza, sin embargo para su mayor seguridad lee las instrucciones abajo para evitar accidentes:

- Desconecte la maquina de la red eléctrica cuando desear hacer la limpieza, la manutención o otro cualquier servicio.
- Nunca usar instrumentos fuera a los que acompañan la maquina para auxiliar en su operación.
- Antes de prender la maquina averigüe si el Vaso N° 02 (Fig.01) está encajado en su posición.
- Mantenga las manos lejanas de las partes movibles.
- Nunca use chorros de agua directamente sobre la maquina.
- Nunca ligue la maquina con las manos, los zapatos o ropas mojadas.
- Cuando se haga la instalación de la maquina no sea olvidado de hacer la conexión de tierra. Una buena conexión a la tierra es importante para la seguridad suya y del equipo.

IMPORTANTE

Este equipo no debe ser utilizado por personas (incluso niños) con debilidades físicas o mentales, o con falta de experiencia o conocimiento, a no ser que tengan recibido instrucciones referente al uso de este equipo por una persona responsable por la seguridad de los mismos.

IMPORTANTE

Si el cable de alimentación no estuviera en buenas condiciones de uso, este deberá ser sustituido, sea por el fabricante, un asistente técnico autorizado o por una persona calificada, para que se evite accidentes.



1.2 Principales Componentes

Todos los componentes que incorporan la maquina son construidos con materiales cuidadosamente seleccionados para su función, dentro de los padrones de prueba y de la experiencia de SIEMSEN.

Foto – 01

- 01 – Tapa del Vaso
- 02 – Vaso
- 03 – Flange del Vaso
- 04 – Flange Soporte Motor
- 05 – Gabinete
- 06 – Base
- 07 – Llave Selectora de Voltaje 110/220V
- 08 – Llave Liga/Desliga



13 Características Técnicas Tabla - 01

Datos Tecnicos	Unidad	LAR-10
Voltaje	[V]	127 / 220
Frecuencia	[Hz]	50 or 60
Potencia	[CV]	0,5
Consumo	[kW/h]	0,38
Altura	[mm]	760
Anchura	[mm]	330
Profundidad	[mm]	320
Peso Neto	[kg]	9,8
Peso Bruto	[kg]	11,2
Rotación	[rpm]	3500

*La frecuencia sera unica de acuerdo a la del motor de la maquina.

2 INSTALACIÓN Y PRE OPERACIÓN

2.1 Instalación

La Licuadora Industrial debe ser instalada sobre una superficie de trabajo estable y plana con preferencialmente 850mm de altura.